



SPHERION TRI LED



User Instructions

Spherion Tri LED

General Information

Unpacking: Thank you for purchasing the Spherion Tri LED by American DJ®. Every Spherion Tri LED has been thoroughly tested and has been shipped in perfect operating condition. Carefully check the shipping carton for damage that may have occurred during shipping. If the carton appears to be damaged, carefully inspect your fixture for any damage and be sure all equipment necessary to operate the unit has arrived intact. In the event damage has been found or parts are missing, please contact our toll free customer support number for further instructions. Do not return this unit to your dealer without first contacting customer support.

Introduction: The Spherion Tri LED is part of American DJ's continuing pursuit for creating and upgrading affordable intelligent fixtures. The Spherion Tri LED is an DMX intelligent centerpiece. This fixture can be used as a stand alone piece or connected in a Master/Slave configuration. The unit can sound active, run in a auto mode or be controlled via DMX controller. When used in DMX mode the fixture has a 1 Channel mode and a 3 Channel mode.

Customer Support: American DJ® provides a toll free customer support line, to provide set up help and to answer any question should you encounter problems during your set up or initial operation. You may also visit us on the web at www.americandj.com for any comments or suggestions. Service Hours are Monday through Friday 9:00 a.m. to 4:30 p.m. Pacific Standard Time.

Voice: (800) 322-6337

Fax: (323) 582-2941

E-mail: support@americandj.com

To purchase parts online visit <http://parts.americandj.com>

Warning! To prevent or reduce the risk of electrical shock or fire, do not expose this unit to rain or moisture.

Caution! There are no user serviceable parts inside this unit. Do not attempt any repairs yourself, doing so will void your manufactures warranty. In the unlikely event your unit may require service please contact American DJ®.

Spherion Tri LED

General Instructions

Please carefully read and understand the instructions in this manual thoroughly before attempting to operate this unit. These instructions contain important safety information regarding the use and maintenance of this unit. Please keep this manual with the unit, for future reference.

Spherion Tri LED

Product Registration

The Spherion Tri LED carries a 3 year (1095 days) limited warranty. Please fill out the enclosed warranty card to validate your purchase. All returned service items whether under warranty or not, must be freight pre-paid and accompany a return authorization (R.A.) number. If the unit is under warranty, you must provide a copy of your proof of purchase invoice. Please contact American DJ® customer support for a R.A. number.

Spherion Tri LED

Main Features

- Bright 3 Watt LED
- 2 DMX Channel Modes - 1 Channel Mode & 3 Channel Mode
- DMX-512 Compatible
- Master/Slave Operation
- 4 Operating Modes - DMX Control, Sound Active, Show Mode, & Program Mode.
- Optional UC3 Controller Compatible (Not Included)

Spherion Tri LED

Safety Precautions

- To reduce the risk of electrical shock or fire, do not expose this unit rain or moisture
- Do not spill water or other liquids into or on to your unit.
- Be sure that the local power outlet match that of the required voltage for your unit.
- Do not attempt to operate this unit if the power cord has been frayed or broken.
- Do not attempt to remove or break off the ground prong from the electrical cord. This prong is used to reduce the risk of electrical shock and fire in case of an internal short.
- Disconnect from main power before making any type of connection.
- Do not remove the cover under any conditions. There are no user serviceable parts inside.
- Never operate this unit when it's cover is removed.
- Never plug this unit in to a dimmer pack
- Always be sure to mount this unit in an area that will allow proper ventilation. Allow about 6" (15cm) between this device and a wall.
- Do not attempt to operate this unit, if it becomes damaged.
- This unit is intended for indoor use only, use of this product outdoors voids all warranties.
- During long periods of non-use, disconnect the unit's main power.
- Always mount this unit in safe and stable matter.
- Power-supply cords should be routed so that they are not likely to be walked on or pinched by items placed upon or against them, paying particular attention to cords at plugs, convenience receptacles, and the point where they exit from the appliance.
- Cleaning -The fixture should be cleaned only as recommended by the manufacturer. See page 16 for cleaning details.
- Heat -The appliance should be situated away from heat sources such as radiators, heat registers, stoves, or other appliances (including amplifiers) that produce heat.
- The fixture should be serviced by qualified service personnel when:
 - A. The power-supply cord or the plug has been damaged.
 - B. Objects have fallen, or liquid has been spilled into the appliance.
 - C. The appliance has been exposed to rain or water.
 - D. The appliance does not appear to operate normally or exhibits a marked change in performance.

Power Supply: The American DJ® Spherion Tri LED contains an electronic ballast, which will auto sense the voltage when it is plugged into the power source. With the electronic ballast you do not need to worry about wall voltage, this unit can be plugged in anywhere.

DMX-512: DMX is short for Digital Multiplex. This is a universal protocol used by most lighting and controller manufactures as a form of communication between intelligent fixtures and controllers. A DMX controller sends DMX data instructions from the controller to the fixture. DMX data is sent as serial data that travels from fixture to fixture via the DATA “IN” and DATA “OUT” XLR terminals located on all DMX fixtures (most controllers only have a DATA “OUT” terminal).

DMX Linking: DMX is a language allowing all makes and models of different manufactures to be linked together and operate from a single controller, as long as all fixtures and the controller are DMX compliant. To ensure proper DMX data transmission, when using several DMX fixtures try to use the shortest cable path possible. The order in which fixtures are connected in a DMX line does not influence the DMX addressing. For example; a fixture assigned a DMX address of 1 may be placed anywhere in a DMX line, at the beginning, at the end, or anywhere in the middle. Therefore, the first fixture controlled by the controller could be the last fixture in the chain. When a fixture is assigned a DMX address of 1, the DMX controller knows to send DATA assigned to address 1 to that unit, no matter where it is located in the DMX chain.

Data Cable (DMX Cable) Requirements (For DMX and Master/Slave Operation): The Spherion Tri LED can be controlled via DMX-512 protocol. The Spherion Tri LED can be either a 1 or 3 channel DMX unit. The DMX address is set electronically using the controls on the rear panel of the unit. Your unit and your DMX controller require an approved DMX-512 110 Ohm Data cable for data input and data output (Figure 1). We recommend Accu-Cable DMX cables. If you are making your own cables, be sure to use standard 110-120 Ohm shielded cable (This cable may be purchased at almost all professional sound and lighting stores). Your cables should be made with a male and female XLR connector on either end of the cable. Also



Figure 1

remember that DMX cable must be daisy chained and cannot be split. cable.

Notice: Be sure to follow figures two and three when making your own cables. Do not use the ground lug on the XLR connector. Do not connect the cable’s shield conductor to the ground lug or allow the shield conductor to come in contact with the XLR’s outer casing. Grounding the shield could cause a short circuit and erratic behavior.

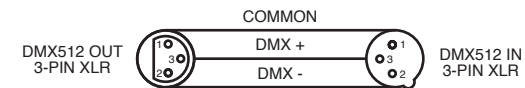

Figure 2

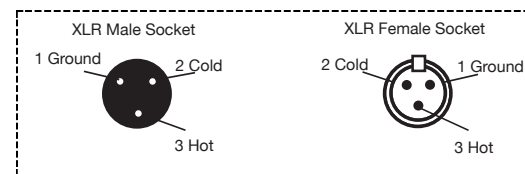

Figure 3

| XLR Pin Configuration |
|------------------------------------|
| Pin 1 = Ground |
| Pin 2 = Data Compliment (negative) |
| Pin 3 = Data True (positive) |

Special Note: Line Termination. When longer runs of cable are used, you may need to use a terminator on the last unit to avoid erratic behavior. A terminator is a 110-120 ohm 1/4 watt resistor which is connected between pins 2 and 3 of a male XLR connector (DATA + and DATA -). This unit is inserted in the female XLR connector of the last unit in your daisy chain to terminate the line. Using a cable terminator (ADJ part number Z-DMX/T) will decrease the possibilities of erratic behavior.



Termination reduces signal errors and avoids signal transmission problems and interference. It is always advisable to connect a DMX terminal, (Resistance 120 Ohm 1/4 W) between PIN 2 (DMX-) and PIN 3 (DMX +) of the last fixture.

Figure 4

Spherion Tri LED

Set Up

5-Pin XLR DMX Connectors. Some manufactures use 5-pin DMX-512 data cables for DATA transmission in place of 3-pin. 5-pin DMX fixtures may be implemented in a 3-pin DMX line. When inserting standard 5-pin data cables in to a 3-pin line a cable adaptor must be used, these adaptors are readily available at most electric stores. The chart below details a proper cable conversion.

| 3-Pin XLR to 5-Pin XLR Conversion | | |
|-----------------------------------|------------------------|---------------------|
| Conductor | 3-Pin XLR Female (Out) | 5-Pin XLR Male (In) |
| Ground/Shield | Pin 1 | Pin 1 |
| Data Compliment (- signal) | Pin 2 | Pin 2 |
| Data True (+ signal) | Pin 3 | Pin 3 |
| Not Used | | Pin 4 - Do Not Use |
| Not Used | | Pin 5 - Do Not Use |

Spherion Tri LED

System Menu

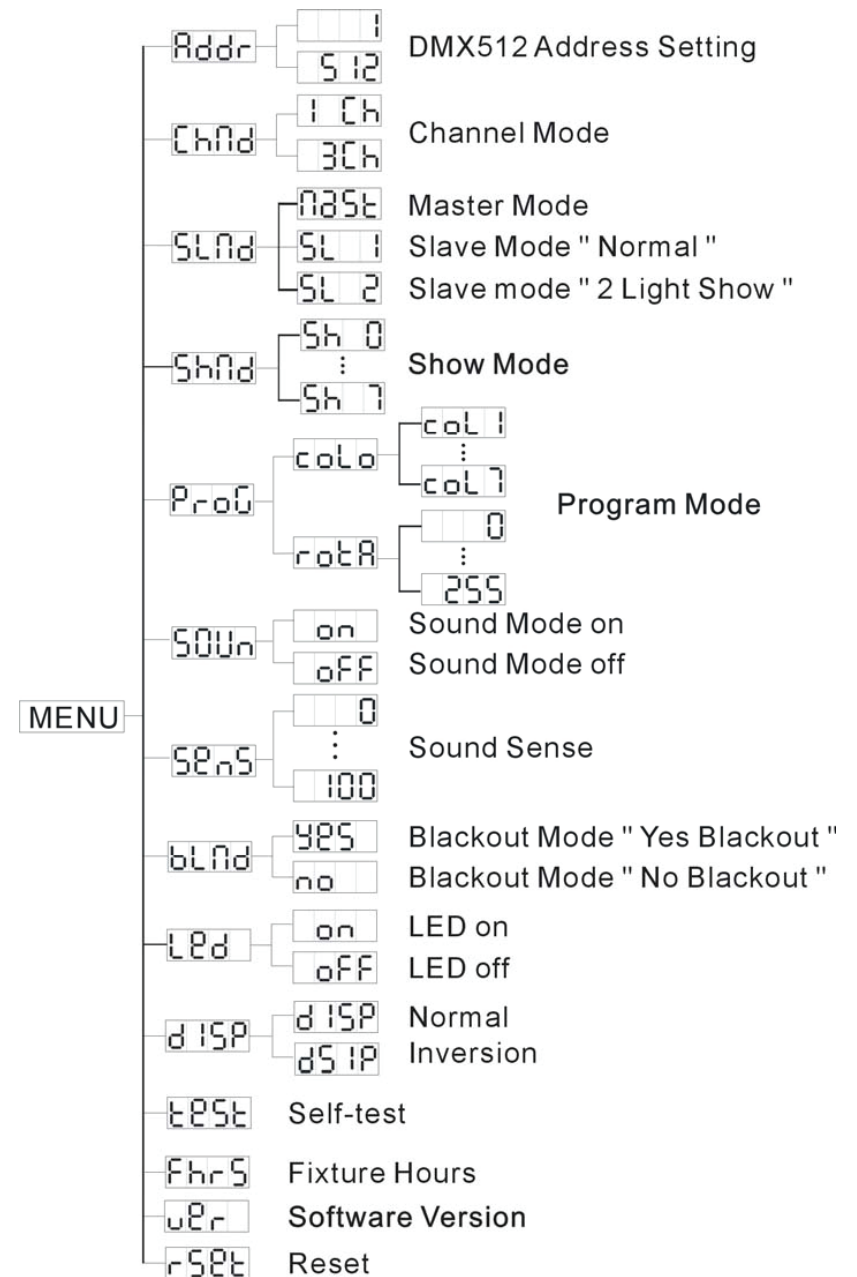

Operating Modes: The Spherion Tri LED can operate in four different modes. In each mode you can run the fixture as a stand alone fixture or in a master/slave configuration. This next section will detail the differences in the operating modes.

- **Sound Active mode -**

The fixture will react to sound.

- **Show mode -**

Choose 1 of 7 show modes to run.

- **Program mode -**

Choose 1 of 7 show modes to run.

- **DMX control mode -**

This function will allow you to control each individual fixtures traits with a standard DMX-512 controller such as the Elation® Show Designer.™

System Menu: When making adjustments you can press **ENTER** to confirm your setup or you can wait 8 seconds for automatic setup. To exit without making any adjustments press the **MENU** button.

ADDR - DMX Address Setting. See page 14 for more information on DMX Control.

1. Press the either the MENU, UP, or DOWN buttons until “ADDR” is displayed, press ENTER.
2. The current address will now be displayed and flashing. Press the UP or DOWN buttons to find your desired address. Press ENTER to set your desired DMX address.

CHND - This will let select your desired DMX mode.

1. Press the either the MENU button until “CHND” is displayed, press ENTER. Either “1CH” or “3CH” will be displayed
2. Press the UP or DOWN buttons to choose your desired DMX mode and press ENTER to confirm and exit.

SLND - This will let you set unit as a master or slave in a master/slave configuration.

1. Press the MENU button until “SLND” is displayed, press ENTER. Either “MAST”, “SL 1” or “SL 2” will be displayed.
2. Press the UP or DOWN buttons until your desired setting is displayed, press ENTER to confirm.

NOTE: In a Master/Slave configuration you can set one fixture to Master and then set the next fixture to “SL 2”, the fixtures will now have contrast movement to each other.

SHND: SH 0 - SH 7 - Show modes 0-7 (Factory programs). Show mode can be run with sound activity or without. For show mode to run without sound activity turn sound activity off.

1. Press the MENU button until “SHND” is displayed, press ENTER.
2. “Sh X” will now be displayed, “X” representing a number between 0-7. Programs 0-7 are factory programs, while “Sh 0” is random mode. Press the UP or DOWN buttons to find your desired show and press the ENTER, then press and hold the MENU button for at least 3 seconds to confirm.

Note: While running a Show, you can change the show instantly by pressing the UP or DOWN buttons.

PROG - In this mode you can choose 1 of 7 colors and control rotation and rotation speed.

1. Press the MENU button until “PROG” is displayed, press ENTER.
2. “CoLo” will now be displayed, press ENTER. “CoLX” will now be displayed, “X” representing a number between 1-7. Use the UP or DOWN buttons to scroll through the different colors. Once you

have found your desired color press ENTER.

3. Press the UP or DOWN button so that “ROT” is displayed. In this setting you can control rotation. Press the ENTER button, “XXX” will be displayed. “XXX” representing a number between 0-255.

0-9 is no rotation, 10-113 is clockwise rotation fast-slow, 114-141 is no rotation, 142-245 is counter-clockwise rotation slow-fast, and 248-255 is no rotation.

4. Adjust the rotation as you desire, then press ENTER.

SOUN - Sound Active mode.

1. Press the MENU button until “SOUN” is displayed, press ENTER.

2. The display will show either “ON” or “OFF”. Press the UP or DOWN buttons to select “ON” to activate sound active mode, or “OFF” to deactivate sound active mode.

3. Press the ENTER, and then press and hold the MENU button for at least 3 seconds to confirm.

SENS - Sound sensitivity control.

1. Press the MENU button until “SENS” is displayed, press ENTER.

2. The display will show a number between 0-100. Press the UP or DOWN buttons to adjust the sound sensitivity. 0 being the least sensitive and 100 the most sensitive.

3. Press the ENTER, and then press and hold the MENU button for at least 3 seconds to confirm.

BLND - Blackout or Stand by mode.

1. Press the MENU button until “BLND” is displayed, press

ENTER. Either Yes or No will be displayed.

2. To activate Blackout tap the UP or DOWN buttons until “Yes” is displayed, press ENTER to confirm. The fixture will now be in Blackout mode. To deactivate Blackout mode, select “No” and press Enter.

LED - With this function you can have the LED display turn off after 10 seconds.

1. Press the MENU button until “LED” is displayed, press ENTER.

2. The display will show either “ON” or “OFF”. Press the UP or DOWN buttons to select “ON” to keep the LED display on at all times, or “OFF” to switch to have the LED display switch off after 10 seconds.

3. Press ENTER to confirm.

DISP - This will “flip” the LED display 180°.

1. Press the MENU button until “disp” is displayed, press ENTER.

2. Either “disp” or “dSiP” will now be displayed. Press the UP or DOWN buttons to select one or the other.

3. Press the ENTER, and then press and hold the MENU button for at least 3 seconds to confirm.

TEST - This function will run a self test program.

1. Press the MENU button until “TEST” is displayed, press ENTER.

2. The fixture will now run a self test.

FHRS - With this function you can display the running time

of the fixture.

1. Press the MENU button until “FHR5” is displayed, press ENTER.
2. The running time of the fixture will now be displayed. Press MENU to exit.

VER - With this function you can display the version software of the fixture.

1. Press the MENU button until “VER” is displayed, press ENTER.
2. The software version will now be displayed. Press MENU to exit

RSET - Use this function to reset the unit.

1. Press the MENU button until “RSET” is displayed, press ENTER.
2. The fixture will now reset

Universal DMX Control: This function allows you to use a Elation® universal DMX-512 controller to control the chases and patterns, dimmer and strobe. A DMX controller allows you to create unique programs tailored to your individual needs.

1. The Spherion Tri LED can be either a 1 or 3 DMX channel fixture. See page 15 for detailed description of the DMX values and traits.
2. To control your fixture in DMX mode, follow the set-up procedures on pages 6-8 as well as the set-up specifications that are included with your DMX controller.
3. Use the controller’s faders to control the various DMX fixture traits.
4. This will allow you to create your own programs.
5. Follow the instructions on page 9 to set the DMX address.
6. For longer cable runs (more than a 100 feet) use a terminator on the last fixture.
7. For help operating in DMX mode consult the manual included with your DMX controller.

Master-Slave Operation This function will allow you to link up to 16 units together and operate without a controller. The units will be sound activated. In Master-Slave operation one unit will act as the controlling unit and the others will react to the controlling units programs. Any unit can act as a Master or as a Slave.

1. Using approved DMX data cables, daisy chain your units together via the XLR connector on the rear of the units. Remember the Male XLR connector is the input and the Female XLR connector is the output. The first unit in the chain (master) will use the female XLR connector only - The last unit in the chain will use the male XLR connector only. For longer cable runs we suggest a terminator at the last fixture.
2. On the Master unit find and run your desired operating mode.
3. On the slave units tap the MENU button until “SLND” is displayed, and Press ENTER. See page 9 under “SLND” for more information.
4. The slave units will now follow the Master unit.

| Spherion Tri LED 1 DMX Channel Mode - DMX Traits | | |
|--|-----------|--------------------------|
| Channel | Value | Function |
| 1 | 0 - 7 | <u>SHOWS</u> BLACKOUT |
| | 8 - 47 | SHOW 1 |
| | 48 - 87 | SHOW 2 |
| | 88 - 127 | SHOW 3 |
| | 128 - 167 | SHOW 4 |
| | 168 - 207 | SHOW 5 |
| | 208 - 247 | SHOW 6 |
| | 248 - 255 | SOUND ACTIVE |

| Spherion Tri LED 3 DMX Channel Mode - DMX Traits | | |
|--|-----------|---|
| Channel | Value | Function |
| 1 | 0 - 9 | <u>ROTATION</u> STOP |
| | 10 - 113 | CLOCKWISE ROTATION FAST-SLOW |
| | 114 - 141 | STOP |
| | 142 - 245 | COUNTER-CLOCKWISE ROTATION FAST - SLOW |
| | 246 - 247 | STOP |
| | 248 - 255 | SOUND ACTIVE |
| | 2 | 0 - 7 |
| 8 - 199 | | DIMMER 0% - 100% |
| 200 - 247 | | STROBING FAST - SLOW |
| 248 - 255 | | ON |
| 3 | | 0 - 46 |
| | 47 - 85 | COLOR 2 |
| | 86 - 124 | COLOR 3 |
| | 125 - 163 | COLOR 4 |
| | 164 - 202 | COLOR 5 |
| | 203 - 240 | COLOR 6 |
| | 241 - 255 | COLOR 7 |

| Spherion Tri LED | | UC3 Control | |
|------------------|---|--|-------------------------|
| Blackout | Blackout the unit | | |
| Function | 1. Synchronous Strobe in white 2. Asynchronous Strobe in white 3. Sound Strobe in color | Select color 1. Red 2. Green 3. Blue 4. Red+Green 5. Green+Blue 6. Red+Blue 7. Red+Green+Blue 8. Color change by sound | Select Show(1-7) |
| Mode | Sound (LED OFF) | Manual Color (LED ON) | Show(LED slow blinking) |

Spherion Tri LED Fuse Replacement

Disconnect the unit's main power supply. Insert a standard flat head screw driver in to the fuse holder housing. Turn the screwdriver in counter-clockwise direction to remove the fuse holder. Remove the old fuse and discard it, replace the fuse with the same type. Insert the fuse holder back into it's housing and turn in clockwise direction to lock the holder in place.

Spherion Tri LED Cleaning

Fixture Cleaning: Due to fog residue, smoke, and dust cleaning the internal and external optical lenses and mirror should be carried out periodically to optimize light output. Cleaning frequency depends on the environment in which the fixture operates (I.e. smoke, fog residue, dust, dew). In heavy club use we recommend cleaning on a monthly basis. Periodic cleaning will ensure longevity, and crisp output.

1. Use normal glass cleaner and a soft cloth to wipe down the outside casing.
2. Use a brush to wipe down the cooling vents and fan grill.
3. Clean the external optics with glass cleaner and a soft cloth every 20 days.
4. Clean the internal optics with glass cleaner and a soft cloth every 30-60 days.
5. Always be sure to dry all parts completely before plugging the unit back in.

MANUFACTURER'S LIMITED WARRANTY

A. American DJ, Inc. hereby warrants, to the original purchaser, American DJ and American Audio products to be free of manufacturing defects in material and workmanship for a prescribed period from the date of purchase (see specific warranty period on reverse). This warranty shall be valid only if the product is purchased within the United States of America, including possessions and territories. It is the owner's responsibility to establish the date and place of purchase by acceptable evidence, at the time service is sought.

B. For warranty service you must obtain a Return Authorization number (RA#) before sending back the product. Contact American DJ, Inc. Service Department at 800-322-6337. Send the product only to the American DJ, Inc. factory. All shipping charges must be pre-paid. If the requested repairs or service (including parts replacement) are within the terms of this warranty, American DJ, Inc. will pay return shipping charges only to a designated point within the United States. If the entire instrument is sent, it must be shipped in its original package. No accessories should be shipped with the product. If any accessories are shipped with the product, American DJ, Inc. shall have no liability whatsoever for loss of or damage to any such accessories, nor for the safe return thereof.

C. This warranty is void if the serial number has been altered or removed; if the product is modified in any manner which American DJ, Inc. concludes, after inspection, affects the reliability of the product; if the product has been repaired or serviced by anyone other than the American DJ, Inc. factory unless prior written authorization was issued to purchaser by American DJ, Inc.; if the product is damaged because not properly maintained as set forth in the instruction manual.

D. This is not a service contract, and this warranty does not include maintenance, cleaning or periodic check-up. During the period specified above, American DJ, Inc. will replace defective parts at its expense with new or refurbished parts, and will absorb all expenses for warranty service and repair labor by reason of defects in material or workmanship. The sole responsibility of American DJ, Inc. under this warranty shall be limited to the repair of the product, or replacement thereof, including parts, at the sole discretion of American DJ. All products covered by this warranty were manufactured after January 1, 1990, and bear identifying marks to that effect.

E. American DJ, Inc. reserves the right to make changes in design and/or improvements upon its products without any obligation to include these changes in any products theretofore manufactured. No warranty, whether expressed or implied, is given or made with respect to any accessory supplied with products described above. Except to the extent prohibited by applicable law, all implied warranties made by American DJ, Inc. in connection with this product, including warranties of merchantability or fitness, are limited in duration to the warranty period set forth above. And no warranties, whether expressed or implied, including warranties of merchantability or fitness, shall apply to this product after said period has expired. The consumer's and/or Dealer's sole remedy shall be such repair or replacement as is expressly provided above; and under no circumstances shall American DJ, Inc. be liable for any loss or damage, direct or consequential, arising out of the use of, or inability to use, this product.

This warranty is the only written warranty applicable to American DJ and American Audio Products and supersedes all prior warranties and written descriptions of warranty terms and conditions heretofore published.

MANUFACTURER'S LIMITED WARRANTY PERIODS:

- All American Audio Products = 1-year (365 day) Limited Warranty (except V-Plus Series Amplifiers)
- All American Audio V-Plus Series Amplifiers = 3-year (1095 day) Limited Warranty
- American DJ Lighting and American DJ Branded Products = 1-year (365 day) Limited Warranty (Such as: Special Effect Lighting, Intelligent Lighting, UV lighting, Strobos, Fog Machines, Bubble Machines, Mirror Balls, Par Cans, Trussing, Lighting Stands etc. excluding Laser Products, lamps, and Star Tec Series)
- American DJ Laser Products and Star Tec Products = 90-Day Limited Warranty
- American DJ L.E.D. Products = 3-year (1095 day) Limited Warranty (excluding motors which have a 1-year (365 day) Limited Warranty)

| | |
|--------------------------|---|
| Model: | Spherion Tri LED |
| Voltage: | 100v~240v/ 50~60Hz |
| LEDs: | 5 x 3W 3-in-1 TRI LED |
| Colors: | RGB |
| Beam Angle: | 270 Degrees |
| Dimensions: | 12.75" (L) x 8" (W) x 16.75" (H) 320mm x 190mm x 422mm |
| Weight: | 11 Lbs. / 5 Kgs |
| Power Draw: | 27W |
| Fuse: | 1 Amp |
| Duty Cycle: | None |
| DMX: | 1 or 3 DMX Channels |
| Working Position: | Any Safe, Secure Position |
| Warranty: | 3 Year (1095 days) |

Auto Sensing Voltage: *This fixture contains a electronic ballast, which will auto sense the voltage when it is plugged into the power source.*

Please Note: *Specifications and improvements in the design of this unit and this manual are subject to change without any prior written notice.*

©American DJ Supply
 American DJ World Headquarters:
 6122 S. Eastern Ave. Los Angeles, CA 90040 USA
 Tel: 323-582-2650 / Fax: 323-582-2610
 Web: www.americandj.com / E-mail: info@americandj.com

American DJ Europe
 Junostraat 2
 6468 EW Kerkrade
 Netherlands
service@americandj.eu / www.americandj.eu
 Tel: +31 45 546 85 00 / Fax: +31 45 546 85 99