



**IOMMI**



Tony Iommi

*T1100*

**Laney**  
POWER TO THE MUSIC

[www.Laney.co.uk](http://www.Laney.co.uk)

## IMPORTANT SAFETY INSTRUCTIONS

**WARNING:** When using electrical products, basic cautions should always be followed, including the following:

1. Read these instructions.
2. Keep these instructions safe.
3. Heed all warnings.
4. Follow all instructions.
5. Do not use this apparatus near water.
6. Clean only with a dry cloth.
7. Do not block any of the ventilation openings. Install in accordance with manufacturer's instructions.
8. Do not install near any heat sources such as radiators, heat registers, stoves or other apparatus (including amplifiers) that produce heat.
9. An apparatus with Class I construction shall be connected to a mains socket outlet with a protective connection. Do not defeat the safety purpose of the polarized or grounding-type plug. A polarized plug has two blades with one wider than the other. A grounding type plug has two blades and a third grounding prong. The wide blade or third prong is provided for your safety. If the provided plug does not fit into your outlet, consult an electrician for replacement of the obsolete outlet.
10. Protect the power cord from being walked on or pinched, particularly at plugs, convenience receptacles, and the point they exit from the apparatus.
11. Only use attachments/accessories provided by the manufacturer.
12. Use only with a cart, stand, tripod, bracket, or table specified by the manufacturer, or sold with the apparatus. When a cart is used, use caution when moving the cart/apparatus combination to avoid injury from tip-over.
13. The mains plug or appliance coupler is used as the disconnect device and shall remain readily operable. The user should allow easy access to any mains plug, mains coupler and mains switch used in conjunction with this unit thus making it readily operable. Unplug this apparatus during lightning storms or when unused for long periods of time.
14. Refer all servicing to qualified service personnel. Servicing is required when the apparatus has been damaged in any way, such as when power-supply cord or plug is damaged, liquid has been spilled or objects have fallen into the apparatus, the apparatus has been exposed to rain or moisture, does not operate normally, or has been dropped.
15. Never break off the ground pin. Connect only to a power supply of the type marked on the unit adjacent to the power supply cord.
16. If this product is to be mounted in an equipment rack, rear support should be provided.
17. Note for UK only: If the colours of the wires in the mains lead of this unit do not correspond with the terminals in your plug, proceed as follows:
  - a) The wire that is coloured green and yellow must be connected to the terminal that is marked by the letter E, the earth symbol, coloured green or coloured green and yellow.
  - b) The wire that is coloured blue must be connected to the terminal that is marked with the letter N or the colour black.
  - c) The wire that is coloured brown must be connected to the terminal that is marked with the letter L or the colour red.
18. This electrical apparatus should not be exposed to dripping or splashing and care should be taken not to place objects containing liquids, such as vases, upon the apparatus.
19. Exposure to extremely high noise levels may cause a permanent hearing loss. Individuals vary considerably in susceptibility to noise-induced hearing loss, but nearly everyone will lose some hearing if exposed to sufficiently intense noise for a sufficient time.

The U.S. Government's Occupational Safety and Health Administration (OSHA) has specified the following permissible noise level exposures: According to OSHA, any exposure in excess of the above permissible limits could result in some hearing loss. Earplugs or protectors to the ear canals or over the ears must be worn when operating this amplification system in order to prevent a permanent hearing loss, if exposure is in excess of the limits as set forth above. To ensure against potentially dangerous exposure to high sound pressure levels, it is recommended that all persons exposed to equipment capable of producing high sound pressure levels such as this amplification system be protected by hearing protectors while this unit is in operation.

Duration Per Day in Hours	Sound Level dBA, slow response
8	90
6	92
4	95
3	97
2	100
1 1/2	102
1	105
1/2	110
1/4 or less	115

**ATTENTION:** L'utilisation de tout appareil électrique doit être soumise aux précautions d'usage incluant:

1. Lire ces instructions
2. Gardez ce manuel pour de futures références.
3. Prêtez attention aux messages de précautions de ce manuel.
4. Suivez ces instructions.
5. N'utilisez pas cette unité proche de plans d'eau.
6. N'utilisez qu'un tissu sec pour le nettoyage de votre unité.
7. N'obstruez pas les systèmes de refroidissement de votre unité et installez votre unité en fonction des instructions de ce manuel.
8. Ne positionnez pas votre unité à proximité de toute source de chaleur.
9. Un appareil avec la construction de la classe I sera relié à une sortie de douille de forces à un raccordement protecteur. Connectez toujours votre unité sur une alimentation munie de prise de terre utilisant le cordon d'alimentation fourni.
10. Protégez les connecteurs de votre unité et positionnez les câblages pour éviter toutes déconnexions accidentelles.
11. N'utilisez que des fixations approuvées par le fabricant.
12. Lors de l'utilisation sur pied ou pole de support, assurez dans le cas de déplacement de l'ensemble enceinte/support de prévenir tout basculement intempêtif de celui-ci.
13. Les forces branchent ou le coupleur d'appareils est utilisé pendant que le dispositif de débranchement et restera aisément fonctionnel. L'utilisateur devrait permettre l'accès facile à toutes les forces prise, à forces coupleur et à commutateur de forces utilisé en même temps que cette unité le rendant de ce fait aisément fonctionnel. Débranchez cet appareil pendant la foudre donne l' assaut à ou si inutilisé pendant de longues périodes.
14. Seul un technicien agréé par le fabricant est à même de réparer/contrôler votre unité. Celle-ci doit être contrôlée si elle a subit des dommages de manipulation, d'utilisation ou de stockage (humidité,...).
15. Ne déconnectez jamais la prise de terre de votre unité.
16. Si votre unité est destinée à être montée en rack, des supports arriere doivent être utilisés.
17. Note pour les Royaumes-Unis: Si les couleurs de connecteurs du câble d'alimentation ne correspond pas au guide de la prise secteur, procédez comme suit:

- a) Le connecteur vert et jaune doit être connecter au terminal noté E, indiquant la prise de terre ou correspondant aux couleurs verte ou verte et jaune du guide.
- b) Le connecteur bleu doit être connecter au terminal noté N, correspondant à la couleur noire du guide.
- c) Le connecteur marron doit être connecter au terminal noté L, correspondant à la couleur rouge du guide.

18. Cet équipement électrique ne doit en aucun cas être en contact avec un quelconque liquide et aucun objet contenant un liquide, vase ou autre ne devrait être posé sur celui-ci.

19. Une exposition à de hauts niveaux sonores peut conduire à des dommages de l'écoute irréversibles. La susceptibilité au bruit varie considérablement d'un individu à l'autre, mais une large majorité de la population expérimentera une perte de l'écoute après une exposition à une forte puissance sonore pour une durée prolongée.

L'organisme de la santé américaine (OSHA) a produit le guide ci-dessous en rapport à la perte occasionnée: D'après les études menées par le OSHA, toute exposition au delà des limites décrites ce-dessus entrainera des pertes de l'écoute chez la plupart des sujets. Le port de système de protection (casque, oreillette de filtrage,...) doit être observé lors de l'opération cette unité ou des dommages irréversibles peuvent être occasionnés. Le port de ces systèmes doit être observé par toutes personnes susceptibles d'être exposées à des conditions au delà des limites décrites ci-dessus.

Durée par Jour (heures)	Niveau sonore moyen (dBA)
8	90
6	92
4	95
3	97
2	100
1 1/2	102
1	105
1/2	110
1/4 ou inférieur	115

# WICHTIGE SICHERHEITSHINWEISE - DEUSCH

**ACHTUNG:** Beim Einsatz von Elektrogeräten müssen u.a. grundlegende Vorsichtsmaßnahmen befolgt werden:

1. Lesen Sie sich diese Anweisungen durch.
2. Bewahren Sie diese Anweisungen auf.
3. Beachten Sie alle Warnungen.
4. Befolgen Sie alle Anweisungen.
5. Setzen Sie dieses Gerät nicht in der Nähe von Wasser ein.
6. Reinigen Sie es nur mit einem trockenen Tuch.
7. Blockieren Sie keine der Lüftungsöffnungen. Führen Sie die Installation gemäß den Anweisungen des Herstellers durch.
8. Installieren Sie das Gerät nicht neben Wärmequellen wie Heizungen, Heizgeräten, Öfen oder anderen Geräten (auch Verstärkern), die Wärme erzeugen.
9. Ein Apparat mit Aufbau der Kategorie I wird an einen Hauptleitungseinfußungsanschluß mit einem schützenden Anschluss angeschlossen. Beeinträchtigen Sie nicht die Sicherheitswirkung des gepolten Steckers bzw. des Erdungssteckers. Ein gepolter Stecker weist zwei Stifte auf, von denen einer breiter ist als der andere. Ein Erdungsstecker weist zwei Stifte und einen dritten Erdungsstift auf. Der breite Stift bzw. der dritte Stift dient Ihrer Sicherheit. Sollte der beiliegende Stecker nicht in Ihre Steckdose passen, wenden Sie sich bitte an einen Elektriker, um die ungeeignete Steckdose austauschen zu lassen.
10. Schützen Sie das Netzkabel, sodass niemand darauf tritt oder es geknickt wird, insbesondere an Steckern oder Buchsen und ihren Austrittsstellen aus dem Gerät.
11. Verwenden Sie nur die vom Hersteller erhältlichen Zubehörgeräte oder Zubehörteile.
12. Verwenden Sie nur einen Wagen, Stativ, Dreifuß, Träger oder Tisch, der den Angaben des Herstellers entspricht oder zusammen mit dem Gerät verkauft wurde. Wird ein Wagen verwendet, bewegen Sie den Wagen mit dem darauf befindlichen Gerät besonders vorsichtig, damit er nicht umkippt und möglicherweise jemand verletzt wird.
13. Die Hauptleitungen verstopfen, oder Gerätekoppler wird während die Trennung Vorrichtung benutzt und wird bereitwillig funktionell bleiben. Der Benutzer sollte einfachen Zugang zu allen möglichen Hauptleitungen Stecker, zu den Hauptleitungen Koppler und zum Hauptleitungen Schalter erlauben, der in Verbindung mit dieser Maßeinheit benutzt wird, die folglich ihn bereitwillig funktionell bildet. Trennen Sie diesen Apparat während der Blitzstürme oder wenn unbenutzt, für lange Zeitabschnitte.
14. Lassen Sie sämtliche Wartungsarbeiten von qualifizierten Kundendiensttechnikern durchführen. Eine Wartung ist erforderlich, wenn das Gerät in irgendeiner Art beschädigt wurde, etwa wenn das Netzkabel oder der Netzstecker beschädigt wurden, Flüssigkeit oder Gegenstände in das Gerät gelangt sind, das Gerät Regen oder Feuchtigkeit ausgesetzt wurde, nicht normal rbeitet oder heruntergefallen ist.
15. Der Erdungsstift darf nie entfernt werden. Schließen Sie nur an die Stromversorgung der Art an, die am Gerät neben dem Netzkabel angegeben ist.
16. Wenn dieses Produkt in ein Geräte-Rack eingebaut werden soll, muss eine Versorgung über die Rückseite eingerichtet werden.
17. Hinweis – Nur für Großbritannien: Sollte die Farbe der Drähte in der Netzleitung dieses Geräts nicht mit den Klemmen in Ihrem Stecker übereinstimmen, gehen Sie folgendermaßen vor:
  - a) Der grün-gelbe Draht muss an die mit E (Symbol für Erde) markierte bzw. grüne oder grün-gelbe Klemme angeschlossen werden.
  - b) Der blaue Draht muss an die mit N markierte bzw. schwarze Klemme angeschlossen werden.
  - c) Der braune Draht muss an die mit L markierte bzw. rote Klemme angeschlossen werden.
18. Dieses Gerät darf nicht ungeschützt Wassertropfen und Wasserspritzern ausgesetzt werden und es muss darauf geachtet werden, dass keine mit Flüssigkeiten gefüllte Gegenstände, wie z. B. Blumenvasen, auf dem Gerät abgestellt werden.
19. Belastung durch extrem hohe Lärmpegel kann zu dauerhaftem Gehörverlust führen. Die Anfälligkeit für durch Lärm bedingten Gehörverlust ist von Mensch zu Mensch verschieden, das Gehör wird jedoch bei jedem in gewissem Maße geschädigt, der über einen bestimmten Zeitraum ausreichend starkem Lärm ausgesetzt ist. Die US-Arbeitsschutzbehörde (Occupational and Health Administration, OSHA) hat die folgenden zulässigen Pegel für Lärmbelastung festgelegt:

Laut OSHA kann jede Belastung über den obenstehenden zulässigen Grenzwerten zu einem gewissen Gehörverlust führen. Sollte die Belastung die obenstehenden Grenzwerte übersteigen, müssen beim Betrieb dieses Verstärkungsystems Ohrstöpsel oder Schutzvorrichtungen im Gehörgang oder über den Ohren getragen werden, um einen dauerhaften Gehörverlust zu verhindern. Um sich vor einer möglicherweise gefährlichen Belastung durch hohe Schalldruckpegel zu schützen, wird allen Personen empfohlen, die mit Geräten arbeiten, die wie dieses Verstärkungssystem hohe Schalldruckpegel erzeugen können, beim Betrieb dieses Geräts einen Gehörschutz zu tragen.

Dauer pro Tag in Stunden	Geräuschpegel dBA langsame Reaktion
8	90
6	92
4	95
3	97
2	100
1 ½	102
1	105
½	110
¼ oder weniger	115





**CUIDADO:** Cuando use productos electrónicos, debe tomar precauciones básicas, incluyendo las siguientes:

1. Lea estas instrucciones.
2. Guarde estas instrucciones.
3. Haga caso de todos los consejos.
4. Siga todas las instrucciones.
5. No usar este aparato cerca del agua.
6. Limpiar solamente con una tela ceca.
7. No blacker ninguna de las salida de ventilación. Instalar de acuerdo a las instrucciones del fabricante.
8. No instalar cerca de ninguna Fuentes de calor come radiators, estufas, hornos u otros aparatos (incluyendo amplificadores) que produzcan calor.
9. Un aparato con la construcción de la clase I será conectado con un enchufe de zócalo de las cañerías con una conexión protectora. No retire la patilla protectora del enchufe polarizado o de tipo "a Tierra". Un enchufe polarizado tiene dos puntas, una de ellas más ancha que la otra. Un enchufe de tipo "a Tierra" tiene dos puntas y una tercera "a Tierra". La punta ancha (la tercera ) se proporciona para su seguridad. Si el enchufe proporcionado no encaja en su enchufe de red, consulte a un electricista para que reemplace su enchufe obsoleto.
10. Proteja el cable de alimentación para que no sea pisado o pinchado, particularmente en los enchufes, huecos, y los puntos que salen del aparato.
11. Usar solamente añadidos/accesorios proporcionados por el fabricante.
12. Usar solamente un carro, pie, trípode, o soporte especificado por el fabricante, o vendido junto al aparato. Cuando se use un carro, tenga cuidado al mover el conjunto carro/aparato para evitar que se dañe en un vuelco. No suspenda esta caja de ninguna manera
13. Las cañerías tapan o el acoplador de la aplicación se utiliza mientras que el dispositivo de la desconexión y seguirá siendo fácilmente operable. El usuario debe permitir el acceso fácil a cualquier cañería enchufe, a las cañerías acoplador y al interruptor de las cañerías usado conjuntamente con esta unidad así que lo hace fácilmente operable. Desenchufe este aparato durante tormentas del relámpago o cuando es inusitado por períodos del tiempo largos.
14. Para cualquier reparación, acuda a personal de servicio cualificado. Se requieren reparaciones cuando el aparato ha sido dañado de alguna manera, como cuando el cable de alimentación o el enchufe se han dañado, algún líquido ha sido derramado o algún objeto ha caído dentro del aparato, el aparato ha sido expuesto a la lluvia o a la humedad, no funciona de manera normal, o ha sufrido una caída.
15. Nunca retire la patilla de Tierra. Conecte el aparato sólo a una fuente de alimentación del tipo marcado al lado del cable de alimentación.
16. Si este producto va a ser enracado con más equipo, use algún tipo de apoyo trasero.
17. Nota para el Reino Unido solamente: Si los colores de los cables en el enchufe principal de esta unidad no corresponden con los terminales en su enchufe, proceda de la siguiente manera:
  - a) El cable de color verde y azul debe ser conectado al terminal que está marcado con la letra E, el símbolo de Tierra (earth), coloreado en verde o en verde y amarillo.
  - b) El cable coloreado en azul debe ser conectado al terminal que está marcado con la letra N o el color negro.
  - c) El cable coloreado en marrón debe ser conectado al terminal que está marcado con la letra L o el color rojo.
18. Este aparato eléctrico no debe ser sometido a ningún tipo de goteo o salpicadura y se debe tener cuidado para no poner objetos que contengan líquidos, como vasos, sobre el aparato.
19. La exposición a altos niveles de ruido puede causar una pérdida permanente en la audición. La susceptibilidad a la pérdida de audición provocada por el ruido varía segúnla persona, pero casi todo el mundo perderá algo de audición si se expone a un nivel de ruido suficientemente intenso durante un tiempo determinado. El Departamento para la Salud y para la Seguridad del Gobierno de los Estados Unidos (OSHA) ha especificado las siguientes exposiciones al ruido permisibles:  
De acuerdo a OSHA, cualquier exposición que exceda los límites arriba indicados puede producir algún tipo de pérdida en la audición. Protectores para los canales auditivos o tapones para los oídos deben ser usados cuando se opere con este sistema de sonido para prevenir una pérdida permanente en la audición, si la exposición excede los límites indicados más arriba. Para protegerse de una exposición a altos niveles de sonido potencialmente peligrosa, se recomienda que todas las personas expuestas a equipamiento capaz de producir altos niveles de presión sonora, tales como este sistema de amplificación, se encuentren protegidas por protectores auditivos mientras esta unidad esté operando.

Duración por Día en Horas	Nivel de Sonido dBA, Respuesta Lenta
8	90
6	92
4	95
3	97
2	100
1 1/2	102
1	105
1/2	110
1/4 o menos	115

# GENERAL INSTRUCTIONS

	<p>Intended to alert the user to the presence of uninsulated 'Dangerous Voltage' within the products enclosure that may be sufficient to constitute a risk of electrical shock to persons.</p> <p>Ce symbole est utilise pur indiquer a l'utilisateur de ce produit de tension non-isolee dangereuse pouvant etre d'intensite suffisante pour constituer un risque de choc électrique.</p> <p>Este simbolo tiene el proposito de alertar al usuario de la presencia de '(voltaje) peligroso' que no tiene aislamiento dentro de la caja del producto que puede tener una magnitud suficiente como para constituir riesgo de corrientazo.</p> <p>Dieses Symbol soll den Anwender vor unisolierten gefährlichen Spannungen innerhalb des Gehäuses warnen, die von Ausreichender Starke sind, um einen elektrischen Schlag verursachen zu können.</p>
	<p>Intended to alert the user of the presence of important operating and maintenance (Servicing) instructions in the literature accompanying the product.</p> <p>Dieses Symbol soll den Anwender vor unisolierten gefährlichen Spannungen innerhalb des Gehäuses warnen, die von Ausreichender Starke sind, um einen elektrischen Schlag verursachen zu können.</p> <p>Este simbolo tiene el proposito de alertar al usuario de la presencia de instrucciones importantes sobre la operacion y mantenimiento en la literatura que viene con el producto.</p> <p>Dieses Symbol soll den Benutzer auf wichtige Instruktionen in der Bedienungsanleitung aufmerksam machen, die Handhabung und Wartung des Produkts betreffen.</p>
<p><b>CAUTION:</b></p> <p><b>ATTENTION:</b></p> <p><b>PRECAUCION:</b></p> <p><b>VORSICHT:</b></p>	<p>Risk of electrical shock - DO NOT OPEN. To reduce the risk of electrical shock, do not remove the cover. No user serviceable parts inside. Refer servicing to qualified personnel.</p> <p>Risques de choc électrique - NE PAS OUVIRIR Afin de reduire le risque de choc électrique, ne pas enlever le couvercle. Il ne se trouve a l'interieur aucune piece pouvant etre reparable par l'utilisateur. Confier l'entretien a un personnel qualifie.</p> <p>Riesgo de corrientazo - no abra Para disminuir el riesgo de corrientazo, no abra la cubierta. No hay piezas adentro que el pueda reparar. Deje todo mantenimiento a los tecnicos calificados.</p> <p>Risiko - Elektrischer Schlag! Nicht offen! Um das Risiko eines elektrischen Schlages zu vermeiden, nicht die Abdeckung entfernen. Es befinden sich keine Teile darin, die vom Anwender repariert werden können. Reparaturen nur von qualifiziertem Fachpersonal durchführen lassen.</p>
<p><b>WARNING:</b></p> <p><b>ADVERTISSEMENT:</b></p> <p><b>ADVERTENCIA:</b></p> <p><b>ACHTUNG:</b></p>	<p>To prevent electrical shock or fire hazard, do not expose this appliance to rain or moisture. Before using this appliance please read the operating instructions for further warnings.</p> <p>Afin de prevenir les risques de decharge électrique ou de feu, n'exposez pas cet appareil a la pluie ou a l'humidite. Avant d'utiliser cet appareil, lisez les advertissements supplementaires situes dans le guide.</p> <p>Para evitar corrientazos o peligro de incendio, no deja expuesto a la lluvia o humedad este aparato Antes de usar este aparato, lea mas advertencias en la guia de operacion.</p> <p>Um einen elektrischen Schlag oder Feuergefahr zu vermeiden, sollte dieses Gerat nicht dem Regen oder Feuchtigkeit ausgesetzt werden. Vor Inbetriebnahme unbedingt die Bedienungsanleitung lesen.</p>

After unpacking your amplifier check that it is factory fitted with a three pin 'grounded' (or earthed) plug. Before plugging into the power supply ensure you are connecting to a grounded earth outlet.

If you should wish to change the factory fitted plug yourself, ensure that the wiring convention applicable to the country where the amplifier is to be used is strictly conformed to. As an example in the United Kingdom the cable colour code for connections are as follows.

EARTH or GROUND GREEN/YELLOW  
NEUTRAL - BLUE  
LIVE - BROWN



## NOTE

This manual has been written for easy access of information. The front and rear panels are graphically illustrated, with each control and feature numbered. For a description of the function of each control feature, simply check the number with the explanations adjacent to each panel.

Your Laney amplifier has undergone a thorough two stage, pre-delivery inspection, involving actual play testing.

When you first receive your Laney guitar amplifier, follow these simple procedures:

(i) Ensure that the amplifier is the correct voltage for the country it is to be used in.

(ii) Connect your instrument with a high quality shielded instrument cable. You have probably spent considerable money on your amplifier and guitar - don't use poor quality cable it won't do your gear justice.

Please retain your original carton and packaging so in the unlikely event that some time in the future your amplifier should require servicing you will be able to return it to your dealer securely packed.

Care of your Laney amplifier will prolong it's life.....and yours!

Supply Voltage:- Factory Preset	~100V, ~120V, ~220V, ~230V, ~240V 50/60Hz
Mains Fuse:	~100V>~120V ~220V>~240V
HT Fuse	T5A L T2A L
Power Consumption	T1A L
Output Power Rating	300W
Features:	100W
	Twin Channels - Lead & Rhythm
	Switchable Pre-Boost on both Channels - LED indicates active
	EQ - Independent Bass, Mid, Treble on each Channel
	Volume - Independent on each Channel
	Enhance - Independent on each Channel
	Presence - Independent- on each Channel
	Power Amp In Socket
	Pre Amp Out Socket
	Sym Link Sockets
	FX Loop - Side Chain - Insert - Bypass, with FX Return Gain Control
	Footswitchable Channels, Pre-Boost ON/OFF on each Channel, with supplied FS4-TI
	Custom TI Livery, Internal Glow
Loudspeaker Outputs	4 Ohms, 8 Ohms, 2 x 8 Ohms, 16 Ohms, 2 x 16 Ohms
Input Impedance	1M Ohm/100pF
Recommended Ex Cabinet	T1412S
Handles	Yes - Comfortable 90° top mounted
Size	271*678*288 (H*W*D)
Unit Weight	21.5Kg
Packed Weight	25.5Kg



This product conforms to the requirements of the following European Regulations, Directives & Rules:-  
CE Mark (93/68/EEC), Low Voltage (2006/95/EC), EMC (2004/108/EEC),  
RoHS (EU2002/95/EC), WEEE (EU2002/96/EC)



In order to reduce environmental damage, at the end of its useful life, this product must not be disposed of along with normal Household waste to landfill sites. It must be taken to an approved recycling centre according to the recommendations of the WEEE (Waste Electrical and Electronic Equipment) directive applicable in your country.

In the interest of continued development, Laney reserves the right to amend product specification without prior notification.

## WELCOME

Dear Player,

Thank you very much for purchasing your new Laney product and becoming part of the worldwide Laney family. Each and every Laney unit is designed and built with the utmost attention to care and detail, so I trust yours will give you many years of enjoyment.

Laney products have a heritage which stretches back to 1967 when I first began building valve amplifiers in my parent's garage.

Since then we have moved on from strength to strength developing an extensive range of guitar, bass, public address and keyboard amplification products along with a list of Laney endorsees that includes some of the world's most famous and respected musicians.

At the same time we believe we have not lost sight of the reason Laney was founded in the first place - a dedication to building great sounding amplification for working musicians.

Warm Regards,

A handwritten signature in black ink, appearing to read 'Lyndon Laney', with a stylized flourish at the end.

Lyndon Laney CEO

***“It began with a clap of thunder and a tolling bell. Then, as a heavily distorted guitar played a diminished fifth – an interval once banned by the Roman Catholic church for being the Devil’s interval – a male voice started to wail as if from the grave..... and music was never the same again.”***

The date was February 13, 1970 and the album was Black Sabbath by Black Sabbath – the guitarist was Tony Iommi and the distorted diminished 5<sup>th</sup> sound was a Laney LA100BL.

Since this auspicious day Laney’s association with Tony Iommi has gone from strength to strength resulting in the launch of his first signature model the GH100TI - originally called the GH100S, almost 20 years ago.

We are extremely proud of our association with Tony Iommi and very happy to be able to announce a new Tony Iommi signature amp – the TI100.

Tony Iommi’s TI100 is a leap forward in guitar tone!

Born out of an exhaustive period of product development, carried out hand in hand with Tony, bringing unique insight, suggestions and innovations at every stage whilst continually assessing and refining the sonic character of guitar tone.

The TI100 features: 100 Watts RMS, 4 x 6L6 output section, twin channels, footswitchable variable PRE BOOST on each channel, 3 band EQ, Volume, Enhance, Presence. All finished off with Tony’s trademark livery and to top it all it even glows an ominous red!

***There are very few chances in life to claim a first, many people can claim to be the biggest or the fastest but only one person can claim to be the first. In the case of Heavy Metal .....the first Heavy Metal guitar tone was crafted by Tony Iommi and powered by Laney.***



## FRONT PANEL CONTROLS

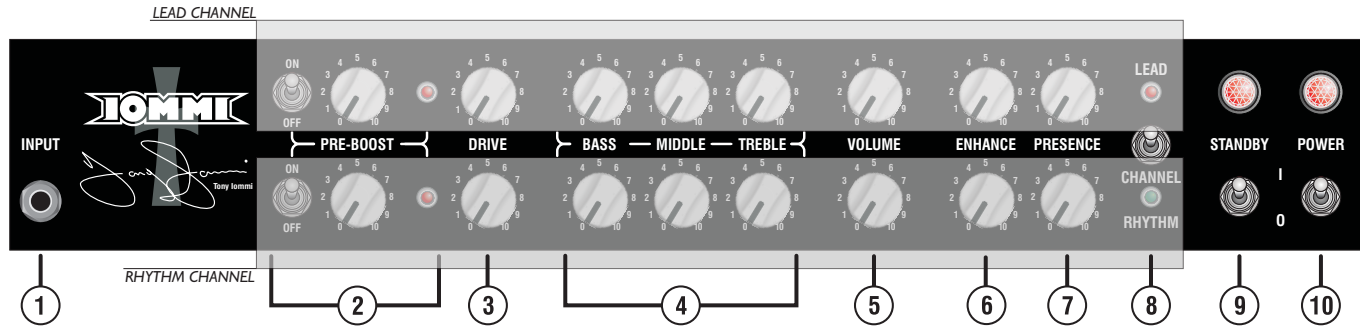

**LEAD & RHYTHM channels are provided, both can have different settings and be switched between with the channel switch (8) or footswitch if connected. Although the functions of the controls on each channel are similar, the sounds can be very different.**

- 1 INPUT:** 1/4" mono jack socket. Connect your guitar here. Use only a good quality instrument cable.
- 2 PRE-BOOST SWITCH:** Switches the input boost circuit on or off. The Pre-Boost circuit increases the input signal to the preamp tubes, just like placing a boost pedal in your signal path. This drives the preamp tubes harder, resulting in more distortion. This works on both channels.
- 3 PRE-BOOST CONTROL:** Controls the level of boost applied to the guitar signal.
- 4 PRE-BOOST LED:** This LED will illuminate when the Pre-Boost controls are activated.
- 3 DRIVE:** Controls the level of preamp distortion on the Lead channel. Turning this control clockwise will add more distortion to your guitar signal, ranging from light overdrive, to full on metal. Use this in conjunction with the Volume Control (5) to achieve the correct volume and distortion level you require.
- 4 EQ CONTROLS:** These are a traditional set of passive tone controls. Passive controls have the advantage of always sounding musical at any of their settings, due to their unique interactive nature. This gives the player a more natural set of tools to shape their ideal sound. Set these midway at (5) as a good starting point.

10

- ⑤ **VOLUME:** Controls the volume of each channel independantly. Experiment with different combinations of the Drive and Volume controls to achieve different sounds. Reducing the Drive while increasing the Volume will result in a warm, open, overdriven sound as the power amp is driven harder, while reducing the Volume and increasing the Drive will give a tighter, more modern sound with more distortion. Once set, try using your guitar's volume controls to interactively adjust tone and distortion levels.
- ⑥ **ENHANCE:** This allows control over the response of the amplifier at lower frequencies. Turning this control clockwise gives a looser low end, while lower settings provide a tighter response. The optimum setting is dependant on the speaker cabinet used.
- ⑦ **PRESENCE:** An output stage tone control. This adjusts the high frequency response - it adjusts your sound from being dull to giving it edge/sounding sparkly.
- ⑧ **CHANNEL SWITCH:** Switches between the Lead and Rhythm channels, the LED lights on the active channel.
- ⑨ **STANDBY SWITCH:** Disconnects the main HT voltage from the tubes but keeps the tubes warm so that they are ready to play instantly. Switch for short breaks when you don't want to wait for the tubes to warm up again. With the switch in the 1 (up) position, the amp is in play mode, while 0 (down) allows the amp to warm up.
- STANDBY LAMP:** This will illuminate when the amplifier is in play mode.
- ⑩ **POWER SWITCH:** Main power switch for the unit. Tube amplifiers take between 30 seconds to 2 minutes to warm up and be ready to play after switching on, this is normal. Use in conjunction with the standby switch to prolong tube life. To turn on, flip the switch to 1 (up).
- POWER LAMP:** This will illuminate when the power switch is operated, indicating the presence of mains power within the amplifier.

**Always switch off  
and disconnect power cord  
when not in use**

## REAR PANEL CONTROLS

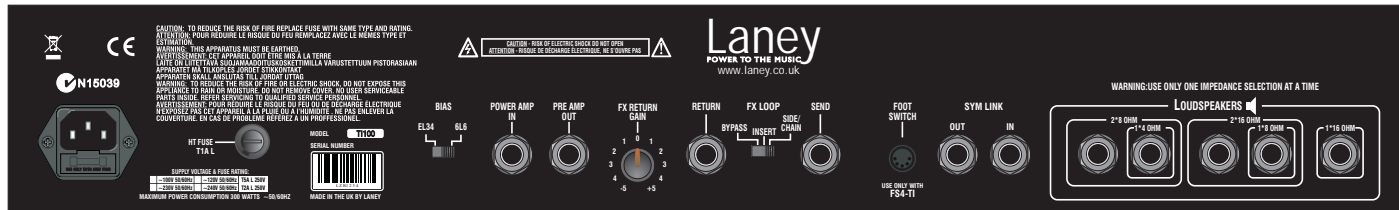

1 Spare fuse located in the fuse drawer. 2

3 4

5

6 7

8

1 **MAINS INLET SOCKET:** Make sure the voltage indicated on the rear panel is correct for your country!

**MAINS FUSE:** This drawer contains the main safety fuse for the unit. The fuse protects the amplifier from damage in the event of fault by disconnecting the mains power supply.

2 **HT FUSE:** This fuse disconnects the high voltage DC power to the tubes within the amplifier in the event of a fault.

**Replacing fuses - USE ONLY THE CORRECT SIZE AND RATING SPECIFIED ON THE PANEL. - Using a fuse that is too large in current rating may cause serious, irreparable damage to the amplifier and presents a serious fire hazard. The fuse ratings are detailed in the Specifications section of this manual, as well as printed on the rear of the amplifier. Fuses are designed to protect, do not take chances.**

3 **BIAS SWITCH:** This allows the use of either 6L6 or EL34 output tubes in your amplifier. Ensure that the switch is in the correct position for your output tubes, otherwise you may risk damaging your amplifier. The T1100 is factory fitted with 4x matched 6L6 tubes. We recommend the use of matched sets of output tubes for optimum performance.

4 **POWER AMP IN:** This socket provides the user with an input to the power amplifier stage. When a Jack is connected to the Line In socket the preamp signal **does not** pass to the power amp.

**PRE AMP OUT:** This socket gives the user an output for driving other amplifiers, mixing desks etc. . Can also be useful in multi-amp setups where a single preamp can drive several power stages. The line out is an (unbalanced) line level output.

**FX RETURN GAIN:** This control serves two purposes:

5 1) **Side Chain Mode:** It controls the mix level of the global FX

2) **Insert Mode:** It behaves as an overall level control for the global FX Return.



**EFFECTS LOOP RETURN:** Connect the output from your external effects to this socket.

**EFFECTS LOOP SWITCH:** This allows the global effects loop to operate in three distinct modes:

- 1) **Side Chain:** The return signal is mixed with the dry signal, the level of FX return is controlled by the FX return level control. This allows you to set the right mix between the dry signal and the effects signal. Use Side chain mode for FX units such as delays, flangers etc where a direct signal path is maintained internally to avoid loss of dynamics through the external FX processor. When using this mode the external FX processor should be switched to 'effect only mode'
- 2) **Insert:** The return signal is buffered and sent directly to the output tubes, no mixing with the dry signal happens. The wet/dry mix is adjusted within the external FX processor. The FX return level control then acts as overall level control allowing you to make up for any insertion loss that may occur in the FX processor. Use this mode when the whole of the amplifier signal needs routing through any external processors such as graphic EQs etc.

**Warning:** *In insert mode with the FX return level control at minimum the amplifier will have no output, a good normal level for this control is '5' which is approx unity gain.*

- 3) **Bypass:** The global FX loop circuitry is switched out of circuit altogether.

**FX SEND:** 1/4" mono jack socket for connection to the input of an external FX unit. This can also be used as a line out for connection to another power amp slave input or for recording.

- 6) **FOOTSWITCH CONNECTIONS:** The T1100 is equipped with a 5 pin DIN socket for the connection of the supplied FS4-TI footswitch, allowing remote operation of the following functions: Channel, Lead Boost on/off & Rhythm Boost on/off.

**SYM LINK:** Link sockets are used when connecting two or more amplifiers together with a single master amplifier. The connection ensures that the slave amplifiers change channels synchronised to the master amplifier. This enables the Presence and Enhance controls on the slave amplifiers to be synchronised with the master amplifier.

**SYM OUT:** Connect a 1/4" mono jack lead from here to a slave amplifier to ensure channel synchronisation.

**SYM IN:** Connect a 1/4" mono jack lead from a master amplifier to ensure channel synchronisation.

- 8) **LOUDSPEAKER CONNECTIONS** Five 1/4" mono jack sockets are provided for the connection of a variety of speaker cabinets. Mismatching your speaker impedance will reduce the performance of your amplifier, and in extreme cases may damage the unit. Never operate any tube amplifier without a load connected: serious irreparable damage may occur.

# QUICK START SETTINGS

## TONY'S TYPICAL SETTINGS

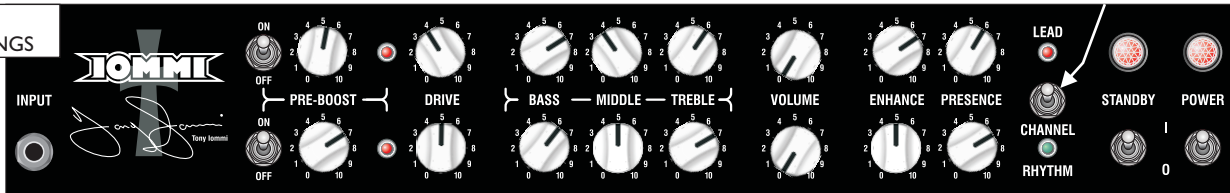

## CLEAN

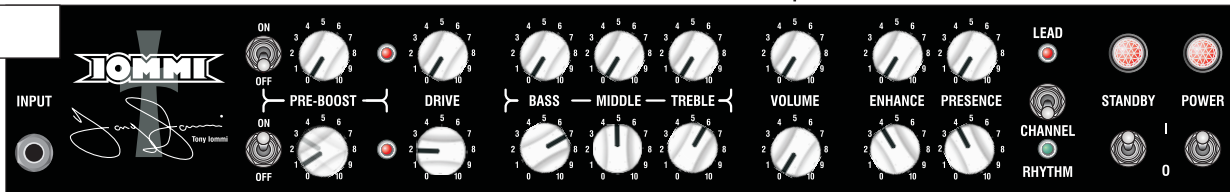

1-3

## CRUNCH

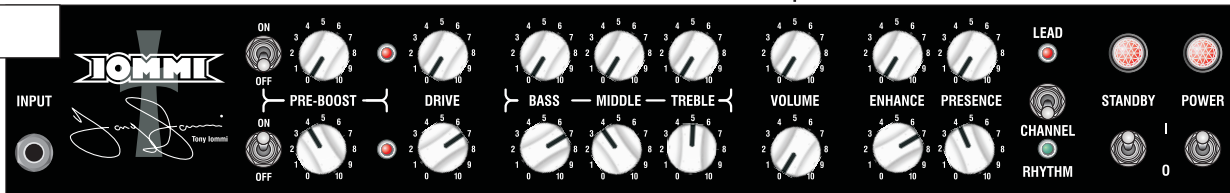

## LEAD

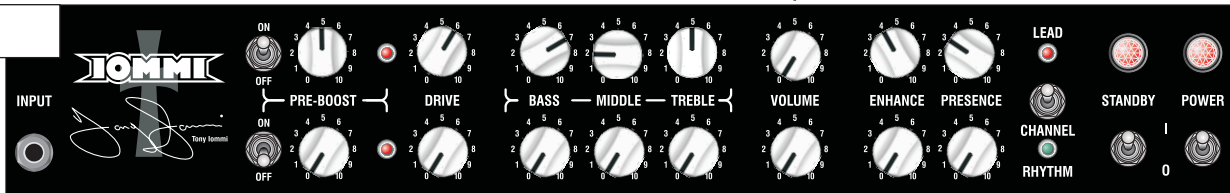

INPUT Terry Holmes

ON/OFF PRE-BOOST DRIVE BASS MIDDLE TREBLE VOLUME ENHANCE PRESENCE LEAD CHANNEL RHYTHM STANDBY POWER

INPUT Terry Holmes

ON/OFF PRE-BOOST DRIVE BASS MIDDLE TREBLE VOLUME ENHANCE PRESENCE LEAD CHANNEL RHYTHM STANDBY POWER

INPUT Terry Holmes

ON/OFF PRE-BOOST DRIVE BASS MIDDLE TREBLE VOLUME ENHANCE PRESENCE LEAD CHANNEL RHYTHM STANDBY POWER

INPUT Terry Holmes

ON/OFF PRE-BOOST DRIVE BASS MIDDLE TREBLE VOLUME ENHANCE PRESENCE LEAD CHANNEL RHYTHM STANDBY POWER

## TUBE AMP TIPS

Tube amplifiers generally sound much warmer/sweeter than solid state transistor amplifiers but they also need a little more respect due to the fragile glass tubes. The T1100 head uses eight 12AX7 preamp tubes, and four 6L6 output tubes which should give you years of trouble free service, however like all tube amps; it is important to treat it with a certain amount of care. Use the following steps as a guide for how to take care of your amplifier:

- Take care when moving the amplifier. Tubes are fragile glass components, they can easily be damaged if thrown in and out of vans.
- Make sure the impedance of your cabinets matches the setting on your amplifier. Improper impedance matching will result in reduced output power and compromised sound at best, and amplifier failure/shortened tube life at worst.
- Allow the amplifier to warm up to room temperature before switching it on: the sudden thermal shock can crack a cold glass tube enclosure, plus any moisture is bad news around high voltage electronics.
- After playing, allow the amplifier to cool down before moving. Hot tubes are more fragile than cool ones.
- Always use good quality loudspeaker cables: instrument cables are not capable of handling the load requirements of the loudspeaker and can short out.

### Replacing Tubes

A tubes life expectancy is based upon a number of factors which include operating temperature, how hard and how often it is played, vibration due to travel, etc. Tubes should be changed in your amplifier if you notice any deterioration in your amplifiers sound or performance. Otherwise, they need not be changed at any regular interval.

Typical problems with preamp tubes can be crackly noise, hiss, hum, and microphony. If they fail or exhibit reduced performance, preamp tubes can simply be swapped out with no further action required.

Typical output tube problems can include a blown HT fuse, sound lacking in punch, sound lacking extreme highs or low, and low level hum. The output tubes can be replaced singly if you replace them with the exact same type AND grade as factory fitted, otherwise they should be replaced as a matched quad set.

To change a tube, firstly switch off and unplug the amplifier from the mains supply. Wait for the tubes to cool down. Remove the rear protective grille held in place with four screws. Preamp tubes are protected with a screen can; to remove, push down and twist the can anti clockwise and then pull up. The tube can now be gently pulled out. Output tubes have a spring retainer which grips the base of the tube; push down on this with one hand, whilst gently rocking the tube with the other to remove. Take care when inserting the new tube in to make sure all pins are correctly aligned. If you have swapped the type of output tube (from 6L6 to EL34 for example) make sure that the bias switch on the rear panel is correctly set before powering on.

The user should not attempt to service this product.  
Please refer all servicing to qualified service personnel.

# BLOCK DIAGRAM

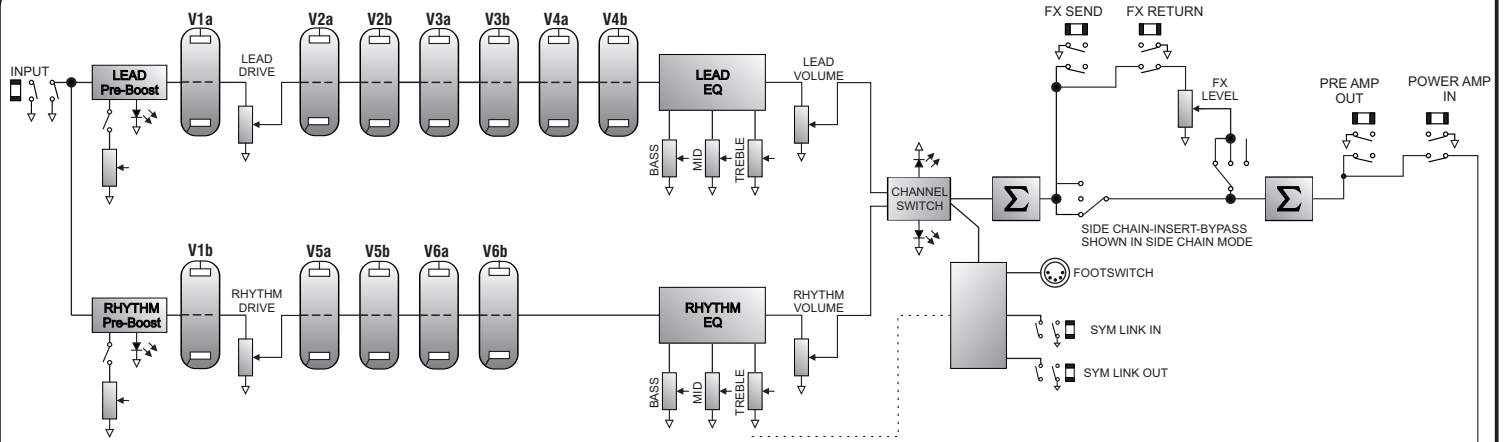

# IOMMI

*Tony Iommi*  
**Tony Iommi**

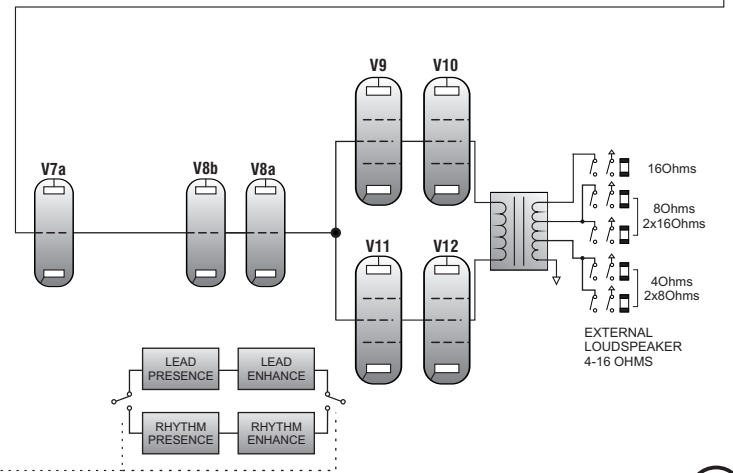



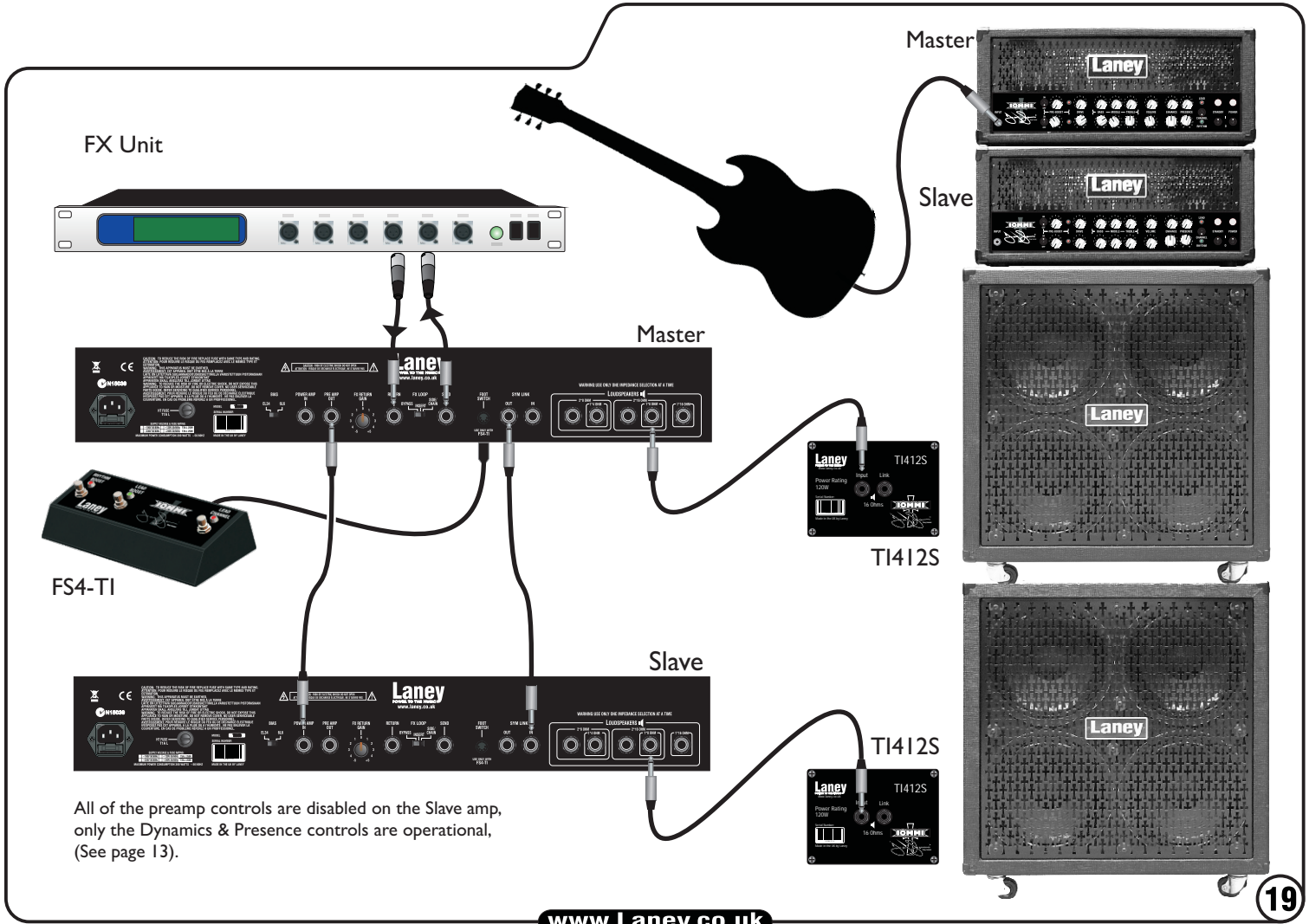

FX Unit

Master

Slave

Master

Slave

FS4-TI

TI412S

TI412S

All of the preamp controls are disabled on the Slave amp, only the Dynamics & Presence controls are operational, (See page 13).

