

GENZ·BENZ

SHUTTLE®

MAX

9.2

Owner's Manual



PRODUCT DESCRIPTION – The SHUTTLE® MAX 9.2 bass amplifier has been designed with our unique ULTRA LIGHT unified design process, yielding a 900 watt professional high powered tour-class bass guitar amplifier weighing only 6.75 lbs! The SHUTTLE® MAX 9.2 is the 2nd generation of Genz Benz SHUTTLE® MAX amplifiers which now incorporates our new 3-Dimensional Power Management circuitry. Our proprietary 3DPM™ technology insures greater and more solid sounding output while retaining the feel and playability of a more traditional tube based power amplifier. When driving the power amp hard, the result is increased heft and girth while maintaining the dynamics and articulation of individual notes. The result is an amplifier that achieves a more 3 dimensional tone and feel, like a tube amplifier power section, without the anemic flatness other amplifier designs can exhibit. This compact design blends the best of analog and digital platforms to produce the ultimate in warmth, punch and power.

The SHUTTLE® MAX 9.2 is equipped with a ¼" unbalanced INSTRUMENT INPUT; input stage overload detector; MUTE switch with LED indicator; FET and 12AX7 TUBE preamps each with HIGH/LOW gain stage settings and 4 band ACTIVE equalization with 2 sweepable midrange bands; 3 switched SIGNAL SHAPE filters with level adjustments; MASTER VOLUME; TUNER OUT; AUX INPUT; 3 EFFECTS LOOPS; balanced DIRECT OUTPUT with GROUND LIFT, PRE or POST EQ; and MIC/LINE switches; HEADPHONE OUTPUT; and 2 Neutrik NL-4 "Speak-on"™ speaker jacks.

The power amp is a powerful, lightweight Class D design and is supported by a state-of-the-art high frequency Switch Mode Power Supply (SMPS), which does away with the weight of a traditional power transformer. The SHUTTLE® 9.2's power supply is usable from 100-240 volts, lending itself well to international touring players.

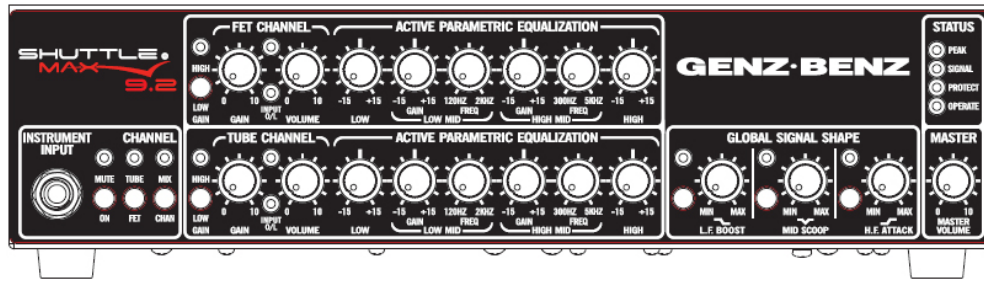

FRONT PANEL

INPUT – The SHUTTLE[®] MAX 9.2 is equipped with a standard ¼” unbalanced INPUT. The INPUT sensitivity range is from 40 mV to over 1.6 volts. The INPUT impedance is >500K ohms. The INPUT stage contains a precision high order active high pass filter (more effective and less intrusive than the more common 6 dB filters) and an “RFI” filter (radio frequency interference) to eliminate unwanted noise. The INPUT gain stages consist of a feedback type variable gain circuit that provides wide range, continuously variable gain with minimal noise. The preamp contains an FET input amp circuit based on our highly regarded GBE series touring amplifiers.

INPUT SIGNAL MUTE SWITCH – With this MUTE switch, you can place the amplifier (and Direct Output) in standby mode between sets, without having to change any of your amp settings. This feature can also be used for silent tuning since the TUNER OUT stays active when the MUTE is engaged. A red LED indicates when the MUTE is active. This function is not operable from the included 5-button footswitch, but a rear panel jack is provided so a standard single button footswitch can be used to remotely engage this function. The switch on the amplifier’s faceplate must be in the out position for the footswitch to work properly.

FET/TUBE CHANNEL SELECTOR SWITCH – This switch is provided to select either the FET channel or the TUBE channel. This function can be remotely engaged via the 5-button footswitch. The front panel switch must be in the out position for the foot switch to engage the function.

CHANNEL MIX SELECTOR SWITCH – When engaged this switch combines the signal of the FET and TUBE channels together. This function can also be remotely engaged via the 5-button footswitch. The front panel switch must be in the out position for the footswitch to engage the function.

FET CHANNEL---

GAIN SWITCH (LOW/HIGH) – This switch sets the GAIN sensitivity for the FET channel. It works somewhat like an Active/Passive switch. The amber LED indicates that the HIGH setting is selected. The difference between the LOW and HIGH gain positions is approx. 10dB. Since there is a GAIN Switch provided for each channel this allows the player to set different gain structures for the FET or TUBE channels. If the cleanest possible signal is desired, we recommend that the LOW setting be used for basses with hotter output or active pickups (those with an output sensitivity over 1 Volt, generally most basses using one or two 9 volt batteries to power their on board preamp) and the HIGH gain setting be used for basses with lower output or passive pickups.

PREAMP GAIN CONTROL – This control sets the GAIN level of the preamp to the output of your bass. If the red OVERLOAD “O/L” LED flashes when setting up your input levels, reduce the preamp gain control to eliminate any input preamp overload. You may want to check the setting of the GAIN switch as well. This GAIN control, in conjunction with the PREAMP VOLUME control allows you to set the signal level to the EQ section. The MASTER VOLUME then controls the total output level of the power amp.

“O/L” LED – In the FET channel this LED senses the condition of the input signal after the GAIN control and also senses and warns of possible clipping in the EQ network. The “O/L” sensing circuit is very dependent upon the output of the bass instrument pickups, the GAIN and VOLUME level settings of the FET channel and the amount of EQ used i.e. the more radical the EQ boost and volume level of the PREAMP VOLUME control, the more possibility of an over-load condition.

If overloading of the FET channel is occurring adjusting the PREAMP GAIN and /or PREAMP VOLUME down will reduce or eliminate the over-load condition and adjusting the MASTER VOLUME up will return the overall loudness.

Note: It is OK for this LED to flash occasionally with your hardest notes played and it may flash even if the TUBE channel has been selected for use. This is normal and is due to the mixing topology for the 2 channels.

PREAMP VOLUME CONTROL – This control sets the volume of the preamp after the INPUT and FET channel gain stages and before the EQ controls. Use this control in conjunction with the GAIN control and the MASTER VOLUME control for your overall output level.

TUBE CHANNEL—

GAIN SWITCH (LOW/HIGH) – This switch sets the GAIN sensitivity for the TUBE channel. It works both like an Active/Passive switch and like a GAIN boost switch. The amber LED indicates that the HIGH setting is selected. The difference between the LOW and HIGH gain positions is approx. 10dB. Since there is a GAIN switch provided for each channel this allows the player to set different gain structures for the FET or TUBE channels.

If warm, clean tube tone is desired, we recommend that the LOW setting be used for basses with hotter output or active pickups (those with an output sensitivity over 1 Volt, generally most basses using one or two 9 volt batteries to power their on board preamp) and the HIGH gain setting be used for basses with lower output or passive pickups. If tube compression, growl, or all-out distortion is desired then the HIGH gain setting may be used regardless of the pickup sensitivity. The “hotter” the pickup output, the more tube distortion can be achieved.

PREAMP GAIN CONTROL – This control sets the input sensitivity gain of the 12AX7 TUBE preamp after the GAIN switch. The design of the TUBE GAIN structure allows you to set your tone from rich, clean tube tone to mild tube compression, to warm tube growl, to all-out aggressive tube overdrive. The volume of the signal is then controlled by the TUBE PREAMP VOLUME control and also the MASTER VOLUME control. The higher the gain settings are, the lower the channel volume will need to be set, so as not to overload the EQ network.

“O/L” LED – In the TUBE channel, this LED senses the condition of the input signal after the GAIN control and also senses and warns of possible clipping in the EQ network. The “O/L” circuit does not sense distortion or overdrive in the tube. Your ears are the best judge of that for your desired tone.

The “O/L” sensing circuit is very dependent upon the output of the bass instrument pickups, the GAIN and VOLUME settings of the FET channel and the amount of EQ used i.e. the more radical the EQ boost and volume level of the PREAMP VOLUME control, the more possibility of an overload condition.

If overloading of the TUBE channel is occurring, adjusting the PREAMP VOLUME and/or PREAMP GAIN controls down will reduce or eliminate the over-load condition and adjusting the MASTER VOLUME control up will return the overall loudness.

Note: It is OK for this LED to flash occasionally with your hardest notes played and it may flash even if the FET channel has been selected for use. This is normal and is due to the Mixing topology for the 2 channels.

PREAMP VOLUME CONTROL – This control sets the volume of the preamp after the INPUT and TUBE gain stages and before the EQ controls. Use this control in conjunction with the PREAMP GAIN control and the MASTER VOLUME control for your overall output level.

ACTIVE EQUALIZATION (both channels) – The SHUTTLE[®] MAX 9.2 contains two active 4 band equalizers (one for the FET and one for the TUBE channel) each with 2 sweepable parametric midrange frequency networks (low mid and high-mid) that offer 15dB of cut or boost with a bandwidth of approximately 1 octave wide. These are slightly over-lapping filters to provide ultimate flexibility.

Parametric filters are typically (but not always) used to reduce or remove offending frequencies in the instrument’s pickup response, or boosting response to achieve a particular voicing. Spend some time experimenting so that the process becomes creative as well as corrective.

LOW FREQUENCY CONTROL – The LOW FREQUENCY EQ section is an 80 Hz shelving curve with 15dB of cut or boost.

LOW-MID FREQUENCY FILTER – The center frequency of the LOW-MID filter is continuously user adjustable from 120 Hz to 2 KHz with a single control. The LOW-MID GAIN control sets the amount of level (cut or boost) for the specific frequency set by the LOW-MID FREQUENCY control.

HIGH-MID FREQUENCY FILTER – The HIGH-MID frequency is continuously user adjustable from 300 Hz to 5 KHz with a single control. The HIGH-MID GAIN control sets the amount of level (cut or boost) for the specific frequency set by the HIGH-MID FREQUENCY control.

HIGH FREQUENCY – The HIGH FREQUENCY EQ section is a 4 KHz shelving curve with 15dB of cut or boost.

NOTE: These equalizer networks are similar to those found on professional sound consoles and are very useful tools. These active equalizers are very wide response type filters and a little “tweaking” goes a long way.

SIGNAL SHAPE – The SHUTTLE® MAX 9.2 is equipped with 3 SIGNAL SHAPE circuits, each with a level control to adjust the amount of level the tone shaping circuit produces.

L.F. BOOST – This filter adds low frequency peaking gain in the 35-65 HZ band range. This is especially effective when used with a 5 string bass. The level control has a range of 0 to +7dB. This filter is unique in that it provides compound, asymmetrical slopes critical to achieving well-controlled low frequency extension.

MID SCOOP -- Engaging this switch generates a midrange frequency cut centered at 600 Hz. The level control adjusts the amount of cut from 0db to –15dB.

H.F. ATTACK -- adds a peaking high frequency boost in the 2.5K – 16 KHz range. The level control has a range of 0 to +7dB.

LED indicators are provided to visually show when each filter is engaged. Each filter Q (bandwidth) is optimized for its particular function and is different for each filter. These functions are also foot-switchable from the 5-button foot-switch.

The switches on the amplifier's faceplate must be in the out position for the footswitch to work properly.

MASTER VOLUME – The MASTER VOLUME control adjusts the overall volume of the amplifier and the effects return. Typically, best results are obtained when this control is operated between the 9:00 and 3:00 positions.

MASTER SECTION STATUS INDICATORS -

- The "POWER" light indicates that the amplifier is ON and the low voltage power supplies are active.
- The red "PROTECT" LED indicates when the amp enters "PROTECT" mode. This LED may flash during power turn-on and turn-off. This is normal. It will also illuminate during any internal fault condition. If this happens, turn the amp off and consult a repair technician.
- The blue "SIGNAL" LED indicates that the power amplifier has received signal (over several watts output) and is performing properly.
- The Amber "PEAK" LED indicates that the power amp has reached maximum power. Under high output conditions it is normal that this LED will light with the strongest pulses of the signal. Driving hard beyond this point will cause the amplifier to gradually begin audible distortion.

GENERAL GUIDELINES FOR SETTING YOUR INPUT SIGNAL – There are a wide variety of variables that can impact your signal and tone in the design of all amplifiers. Below are some basic guidelines to consider when beginning to set your tone on the SHUTTLE® MAX 9.2.

- Begin a basic set up for the FET and TUBE channels with all EQ settings set at the 12 o'clock position.
- If you are using an Active bass, begin with the channel GAIN switches in the LOW positions. For a Passive bass begin with these set in the HIGH position.
- Set the GAIN control for each channel to approx. 10-12 o'clock positions. Now, bring up the PREAMP VOLUME control to approx. the same position ---10-12 o'clock.
- At this time, you may want to set the MASTER VOLUME to the 9 o'clock position.
- From this point you can set your EQ settings to your desired taste.
- If the O/L light on either channel is blinking, you should back down either your PREAMP GAIN control or PREAMP VOLUME control so that it blinks with only the very hardest notes played --- or not at all.
- If you set radical EQ settings this may impact the level of your signal causing the O/L light to engage more. If so, then reduce your PREAMP VOLUME control a little more.
- In the TUBE channel the O/L light will not sense TUBE OVERDRIVE so you will be able to get varying amounts of TUBE compression or distortion without the O/L light coming on. If you do see the O/L light blinking on the TUBE channel, then you will want to reduce your PREAMP VOLUME control.
- As you fine-tune your settings and levels and get your tone ready for a performance level of output, it is suggested you try to keep your PREAMP VOLUME levels and your MASTER VOLUME levels operating in approximately the same range, generally between 9 – 3 o'clock. This is not a hard-fast rule but it is a good starting place.

NOTE----In the TUBE channel if you are using an aggressive TUBE distortion your PREAMP GAIN may be set very high and your PREAMP VOLUME set very low to keep the O/L LED from lighting. In this case the MASTER VOLUME will primarily be used to set your final output level. For heavy distortion, you may want to use the HIGH GAIN switch with a hot Active bass.



REAR PANEL

DIRECT OUTPUT – An XLR balanced DIRECT OUTPUT is provided for connection to a PA system or directly into a recording studio console or D/A converter. The DIRECT OUTPUT signal may be switched between MIC and LINE level, PRE and POST EQ, and the audio signal ground may be connected or lifted from pin 1 with the ground lift switch to eliminate hum due to ground loops. The DIRECT OUTPUT is fully protected against 48 volt phantom power, and may be used for driving microphone lines of up to 300 feet without problems.

AUX INPUT – A 1/4" unbalanced line level AUXILIARY INPUT is provided. It sums directly to the main output bus, and is controlled by the MASTER VOLUME control. This input is ideal for practicing with recorded tracks from a CD player, IPOD, or MP-3 player. This input is a tip-ring-sleeve type jack with built-in summing resistors that sum left and right signals when used with a stereo cable. This input will also work with a mono tip-sleeve plug. Adjust the level of the playback source to balance with the bass guitar's volume.

TUNER OUTPUT – The SHUTTLE[®] MAX 9.2 is equipped with a fully isolated TUNER OUTPUT. This jack is located after the front end scaling preamplifier, but is pre-SIGNAL SHAPE circuits and pre-EQ. This output may also be used to drive a separate direct box or high-impedance recording device. The TUNER OUTPUT remains active when the amplifier is muted with the front panel MUTE switch, allowing silent tuning on stage.

EFFECTS LOOPS – The serial “EFFECTS LOOP” jacks are provided to allow access to the signal for the purpose of inserting signal processing equipment such as compressors, chorus, delay & reverb processors. Individual pre-EQ loops are provided for the TUBE channel and the FET channel. An additional MASTER post EQ loop is provided for the summed (TUBE + FET) signal. This loop may also be used as a PREAMP OUTPUT or POWER AMP INPUT patch point. “SEND” (output) and “RETURN” (input) are nominal +4 dB level.

“Series” devices (such as compressors and gates) require that the signal flow out from the send jack on the amplifier, through the processing device and back into the return jack on the amplifier. Parallel or mixed signal devices (such as chorus, delay and reverb processors) require that the signal flow out of the send jack on the amplifier, through the unit where it is split into a dry (unaltered) signal and a wet (processed) signal. On the processing unit, you will use the mixed signal output to return the signals (both wet and dry) to the return jack on the amplifier. The ratio between the wet signal and the dry signal is heard as the amount of effects added back to the original signal, which is controlled by the mix knob (also called “balance”) on the effects processor. This may be a real knob (as in the Alesis® Microverb), or software controlled (as in the Yamaha SPX-90, SPX900 or SPX 990). Set the input sensitivity on the effects processor according to the manufacturer’s instructions.

The front panel MUTE switch will shut all of these outputs down when engaged.

FOOTSWITCHES – A DIN connector is provided for connecting the included 5-button footswitch. This footswitch controls CHANNEL switching and mixing along with all the GLOBAL SIGNAL SHAPE circuits. Additionally a 1/4” footswitch jack is also provided for switching the MUTE function separately. Any single button latching style footswitch will operate this function.



HEADPHONE OUT – A 1/4” TRS jack is provided for connection to headphones for silent practice use. A speaker load is not required. Do not connect this output to anything but headphones.

POWER AMPLIFIER – The SHUTTLE® 9.2 uses a state of the art, Class D power amplifier design and a high frequency switch-mode power supply (SMPS) to achieve unprecedented high performance and lightweight packaging. Switch-mode power supplies convert the AC line directly to high voltage DC, then the precision PWM (pulse width modulation) inverter creates a new AC power signal at a frequency more than 1000 times higher than the original wall frequency of 50/60Hz. This new high voltage, high frequency power signal is then fed into a custom high frequency transformer that steps the voltage down, a high frequency rectifier and high ESR filter capacitors finish the process off by converting the high frequency AC signal back to the DC voltages that the amplifier’s internal circuitry uses. One advantage of this conversion process is that the DC power supply rails are refreshed more than 1000 times more often than in traditional linear supplies, thus reducing annoying hum in the audio signal. The high frequency switching is used to reduce the size and weight of the magnetic and filter components while increasing the performance by recharging the power supply rails more often. The Class D amplifier uses digital PWM techniques similar to those in more familiar digital to analog converters to reduce the size and weight by a factor of 10 times that of a comparably rated conventional Class AB amplifier. Essentially, a Class D amplifier converts the analog signal into a logic level PWM digital signal with an analog to digital converter, level shifts this PWM signal up to a higher voltage and current and then reconstructs the analog signal by passing it through what is essentially a power digital to analog converter. Additionally, we developed our proprietary 3DPM™ technology to give a distinctly analog feel and sound to the Class D platform. This system provides exceptional performance even for low frequency applications such as bass guitar.

SPEAKER OUTPUTS – The SHUTTLE® 9.2 provides two Neutrik Speak-On™ connectors (wired 1+/1-). The speaker jacks are paralleled. The minimum speaker load is 4 ohms. **Do not ground either the “+” or the “-” outputs.**

POWER INPUT – VOLTAGE SELECTOR SWITCH - The SHUTTLE[®] MAX 9.2 utilizes a selectable universal power supply that operates from 100V to 240 volts, 50 to 60 Hz for worldwide use. Simply set the voltage selector switch to the appropriate AC mains voltage (BEFORE connecting to the power source).

Utilize the proper IEC cord-set appropriate for the country the product is being used. For countries using 100V, 110V, 115V and 120V AC mains, select both voltage selector switches to the 115V position. For countries using 220V, 230V, and 240V AC mains, select both voltage selector switches to the 230V position. There is no externally accessible AC mains (line) fuse. The internal fuse is integral to the SMPS power supply and is not user serviceable. This fuse will not fail except under very unlikely fault conditions to the SMPS, and if this occurs a qualified service technician is required to correct the problem.

CHASSIS DESIGN – The SHUTTLE[®] MAX'S ULTRA LIGHT DESIGN utilizes the highest quality aircraft grade, computer machined aluminum chassis. To clean the amplifier, nothing more than a damp cloth and a little bit of glass cleaner (like Windex[™]) should be used.

Accessories:

RACK MOUNTING – The SHUTTLE[®] MAX is designed to be rack mounted in a standard EIA style 19" equipment rack or tour-case. An optional rack mounting kit is available from your dealer. The part number is: STL-MAX-RK.



GIG-BAG – A custom padded carry bag with shoulder strap is available as an optional accessory from your dealer. The part number is: STL-MAX-BAG. Do not operate the amplifier inside the carry bag, as the chassis aluminum construction and cooling fan inlet vents are part of the amplifier's cooling mechanism.



Specifications

STL-MAX 9.2

Rated Power:

500 Watts @ 8 ohms;

900 Watts @ 4 ohms

Dimensions:

3.5"H X 13.5"W X 13"D

Weight:

6.75 LBS

SAFE OPERATING REQUIREMENTS:

- Never set an amplifier on anything that will tip over or collapse under its weight.
- Provide a minimum distance of 25.4 mm (1 inch) around all sides of the amplifier for sufficient ventilation. The ventilation should not be impeded by covering the amplifier's vent openings with items such as newspapers, table-cloths, curtains, etc.
- No naked flame sources, such as lighted candles, should be placed on the SHUTTLE® MAX 9.2 amplifier.
- This amplifier should not be exposed to dripping or splashing and no objects filled with liquids, such as vases or drinks, shall be placed on this product.
- The SHUTTLE® MAX 9.2 amplifier should be connected to a mains socket outlet (power receptacle) with a protective earth (ground) connection at all times.
- The amplifier's mains plug (power plug) is considered the disconnect device and the connection must remain accessible at all times.
- This amplifier is capable of producing sound pressure levels that may cause hearing loss.
- There are no user serviceable parts and hazardous operating voltages are present inside this unit. Always consult a qualified repair facility for service.

WARNING!

- The use and operation of this device constitutes an agreement of full release of any and all liability connected with its use. Only persons familiar with the operation of high-powered professional audio equipment should attempt to operate this device.
- In addition, by use of this device, the user agrees to hold Genz Benz and its designers, sales agents and all other affiliates and related parties harmless in the event of any accident, injury, damage or loss resulting from such use.
- Manufacturer's sole responsibility is to provide a warranty on the specified performance of the product under normal operating conditions for a period of 3 years.

WARRANTY:

- Genz Benz warrants the SHUTTLE® MAX 9.2 to be free from defects in materials and workmanship for a period of 3 years from the date of purchase, when purchased from an authorized Genz Benz dealer.
- Preamp tubes are warranted for a period of 6 months from the date of purchase.
- This warranty does not cover normal wear and tear incurred from the normally designed use of the product.
- This warranty is effective only if a copy of the original sales receipt is presented at the time of warranty service.
- This limited warranty is completely transferable to any subsequent buyer as long as the original sales receipt is also transferred to such subsequent buyer.
- All warranty service must be performed by a Genz Benz authorized service center.
- Before returning any unit to Genz Benz for service, a returned merchandise authorization number (RMA#) must be obtained by calling 480-941-0705.
- This warranty is valid in the US and Canada only. For all products sold outside the USA, warranty is handled through our international distributor for each country. For more information visit our website www.genzbenz.com

BLOCK CIRCUIT DIAGRAM

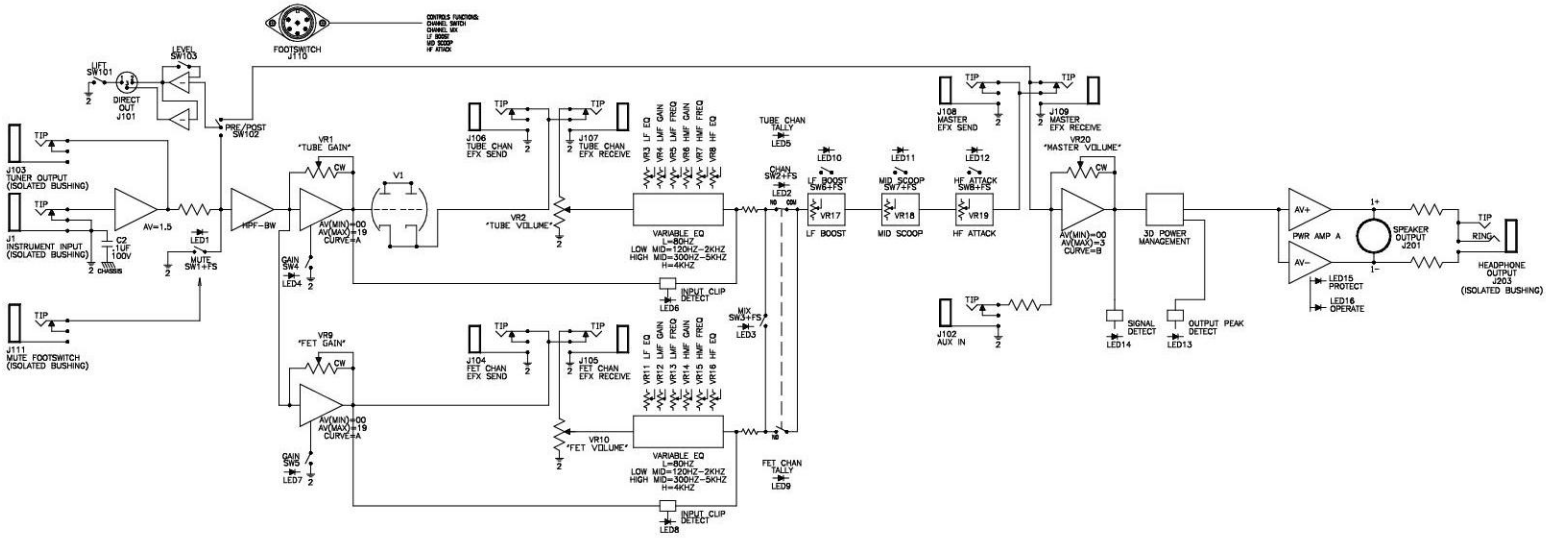

BLOCK DIAGRAM SHUTTLE MAX 9.2

Declaration of Conformity (89/336 EEC-EMC Directive)

Manufacturer's Name: Genz Benz, a division of KMC Music Corporation
 Manufacturer's Address: 7811 East Pierce Street
 Scottsdale, AZ 85257, U.S.A.

Product Type: Audio Amplifier
 Model Number: SHUTTLE[®] MAX (all versions)
 Operating Power Condition: 100/115/230/240 V, 50/60 Hz
 Effective Date: 01-01-2011

Conforms to the Following Standards:

- EN 55013: 2001 + A1: 2003
- EN 55020: 2002 + A1: 2003
- EN 60065: 2001+A1
- IEC 61000-3.3: 1994 + A1: 2001
- IEC 61000-4.2
- IEC 61000-4.3
- IEC 61000-4.4
- FCC 15.107 and 15.109
- RoHS Directive 2002/95/EC
- WEEE Directive 2002/96/EC
- CE Mark LV Directive 73/23 EEC

GENZ·BENZ

7811 E. Pierce St. Scottsdale, AZ 85257
 Ph: 480-941-0705 Fax: 480-946-2412
 www.genzbenz.com

A division of KMC Music Corporation, Bloomfield, CT

Genz Benz and Shuttle[®] Max are trademarks of Genz Benz and KMC Music.