

# **auro**

**X12D • X15D**

**1,000 WATT ACTIVE LOUDSPEAKER**



**OWNER'S MANUAL**

***SAMSON***<sup>®</sup>

Copyright 2014 - Samson Technologies Corp.  
V1  
Samson Technologies Corp.  
45 Gilpin Avenue  
Hauppauge, New York 11788-8816  
Phone: 1-800-3-SAMSON (1-800-372-6766)  
Fax: 631-784-2201  
[www.samsontech.com](http://www.samsontech.com)

# Important Safety Information



This lightning flash with arrowhead symbol within an equilateral triangle is intended to alert the user to the presence of non-insulated "dangerous voltage" within the product's enclosure that may be of sufficient magnitude to constitute a risk of electric shock.



The exclamation point within an equilateral triangle is intended to alert the user to the presence of important operating and maintenance instructions in the literature accompanying the appliance.

**WARNING: TO REDUCE THE RISK OF ELECTRIC SHOCK, DO NOT REMOVE COVER (OR BACK) AS THERE ARE NO USER-SERVICEABLE PARTS INSIDE. REFER SERVICING TO QUALIFIED SERVICE PERSONNEL.**

1. Read these instructions.
2. Keep these instructions.
3. Heed all warnings.
4. Follow all instructions.
5. Do not use this apparatus near water.
6. Clean only with dry cloth.
7. Do not block any ventilation openings. Install in accordance with the manufacturer's instructions.
8. Do not install near any heat sources such as radiators, heat registers, stoves, or other apparatus (including amplifiers) that produce heat.
9. Do not defeat the safety purpose of the polarized or grounding type plug. A polarized plug has two blades with one wider than the other. A grounding type plug has two blades and a third grounding prong. The wide blade or the third prong are provided for your safety. If the provided plug does not fit into your outlet, consult an electrician for replacement of the obsolete outlet.
10. Protect the power cord from being walked on or pinched particularly at the plugs, convenience receptacles, and at the point where they exit from the apparatus.
11. Only use attachments/accessories specified by the manufacturer.
12. Use only with the cart, stand, tripod, bracket, or table specified by the manufacturer, or sold with the apparatus. When a cart is used, use caution when moving the cart/apparatus combination to avoid injury from tip-over.
13. Unplug the apparatus during lightening, storm or when unused for long periods of time.
14. Refer all servicing to qualified personnel. Service is required when the apparatus has been damaged in any way, such as power supply cord or plug is damaged, liquid has been spilled or objects have fallen into the apparatus has been exposed to rain or moisture, does not operate normally, or has been dropped.
15. This appliance shall not be exposed to dripping or splashing water and that no object filled with liquid such as vases shall be placed on the apparatus.
16. Caution-to prevent electrical shock, match wide blade plug wide slot fully insert.
17. Please keep a good ventilation environment around the entire unit.



# Important Safety Information

## FCC Notice

1. This device complies with Part 15 of the FCC Rules. Operation is subject to the following two conditions:
  - (1) This device may not cause harmful interference.
  - (2) This device must accept any interference received, including interference that may cause undesired operation.
2. Changes or modifications not expressly approved by the party responsible for compliance could void the user's authority to operate the equipment.



If you want to dispose this product, do not mix it with general household waste. There is a separate collection system for used electronic products in accordance with legislation that requires proper treatment, recovery and recycling.

Private household in the 28 member states of the EU, in Switzerland and Norway may return their used electronic products free of charge to designated collection facilities or to a retailer (if you purchase a similar new one).

For Countries not mentioned above, please contact your local authorities for a correct method of disposal.

By doing so you will ensure that your disposed product undergoes the necessary treatment, recovery and recycling and thus prevent potential negative effects on the environment and human health.

---

# Contents

Introduction . . . . .	6
Features . . . . .	7
Quick Start . . . . .	8
Rear Panel Layout . . . . .	9
Making Connections . . . . .	11
Cables and Connectors . . . . .	13
Specifications . . . . .	14
Dimensions . . . . .	15

---

## Introduction

Thank you for purchasing the Samson Auro professional, powered loudspeaker. The Auro X12D and X15D are compact and powerful speaker cabinets featuring 1,000 watts of bi-amped onboard power. The Auro X12D and X15D, respectively, feature 12" and 15" heavy-duty, long-excursion woofers, as well as 1.34" titanium compression drivers with a 1" exit. The back panels offer two XLR & ¼" input channels, each with independent volume controls. They also feature a Master Volume control, as well as a 3-position EQ and HPF presets to suit any application. The XLR Line Output allows you to "daisy-chain" multiple Auro cabinets together to create larger sound reinforcement systems.

The Auro X12D and X15D feature a 1,000 watt lightweight, efficient class-d amplifier as well as Samson's R.A.M.P. Digital Signal Processing (DSP) technology. The R.A.M.P. DSP ensures for maximum output with a linear response while providing protection to the speaker and components.

Each cabinet's trapezoidal shape allows it to be configured for either front-of-house use, or for operation as a wedge-style monitor. In addition, the compact cabinets can easily be stacked, using the built-in bumpers or can be stand-mounted using the integral 1 3/8" pole-mount receptacles.

Each Auro PA system's durable enclosure is made of high-impact polypropylene with a scuff-resistant textured finish, and include a heavy-grade steel grill, offering excellent protection against wear and tear for truly portable audio. The Auro active monitors are ideal for live music, DJ, lecture, and installed sound applications, or anywhere serious power and superior sound quality are desired.

In these pages, you'll find a detailed itemization of the features of the Auro PA system, as well as a description of its front and rear panels, step-by-step instructions for its setup and use, and full specifications. You'll also find a warranty card enclosed—please don't forget to fill it out and mail it in so that you can receive online technical support, and so that we can send you updated information about this and other Samson products in the future. Also, be sure to check out our website ([www.samsontech.com](http://www.samsontech.com)) for complete information about our full product line.

With proper care and adequate air circulation, your Auro cabinet will operate trouble free for many years. We recommend you record your serial number in the space provided below for future reference.

Serial number: \_\_\_\_\_

Date of purchase: \_\_\_\_\_

Should your unit ever require servicing, a Return Authorization (RA) number must be obtained before shipping your unit to Samson. Without this number, the unit will not be accepted. Please call Samson at 1-800-3SAMSON (1-800-372-6766) for an RA number prior to shipping your unit. Please retain the original packing materials and, if possible, return the unit in the original carton and packing materials. If you purchased your Samson product outside the United States, please contact your local distributor for warranty and service information.



# Features

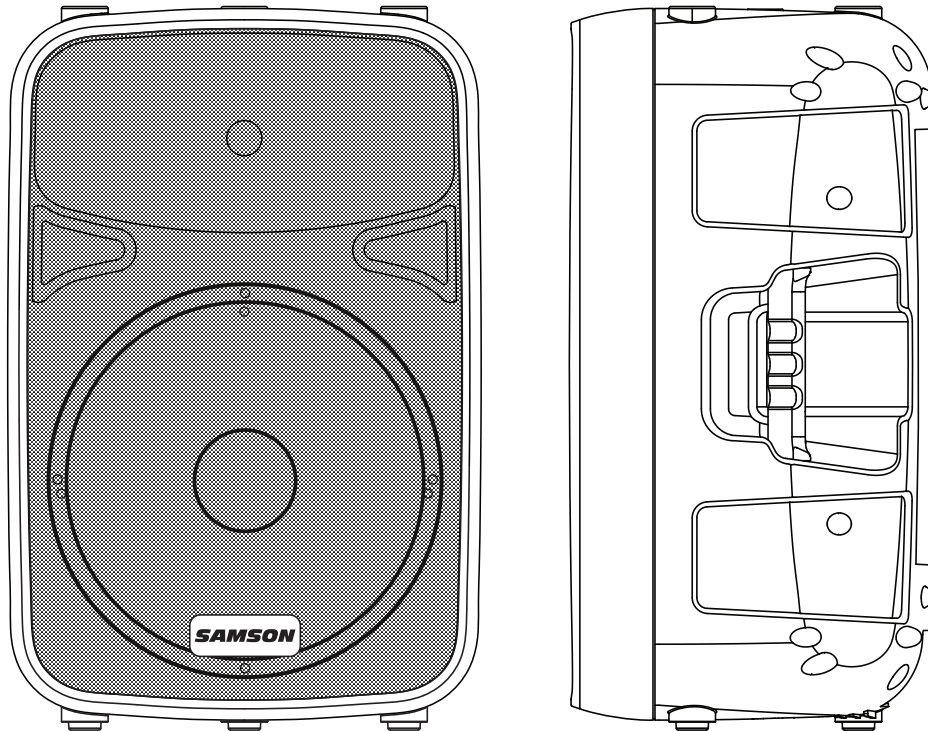

- 1,000 watt, two-way active loudspeakers for live sound applications
- Lightweight, ultra-efficient Class-D amplifier
- 800W LF + 200W HF power amplifiers (peak)
- Ultra-wide, flat frequency response
- Custom-designed, heavy-duty, 12"/15" long throw low frequency drivers provide enhanced bass response
- 1.34" titanium diaphragm compression driver with 1" throat for smooth high-end reproduction
- Samson's R.A.M.P. DSP technology
- Master Volume control with peak indicator
- Two XLR-1/4" combo input channels with independent
- 3-position EQ and HPF presets
- XLR Line Output connectors to "daisy-chain" multiple Auro cabinets
- Internal 24 dB/octave time aligned electronic crossover
- 30- and 45- degree monitor angles for near and far field coverage
- Standard 1 3/8-inch (35mm) speaker stand receptacle
- Versatile, portable design with integrated side handles
- Tuned, ported bass reflex design for extended low end
- Solid polypropylene enclosure with impact resistant design

# Quick Start

1. Turn the Level control on the rear panel fully counterclockwise.
2. Set the HPF and EQ switches to the Flat positions (figure 1).
3. Turn the Power switch OFF.
4. Connect either a line level signal from your mixer (or other audio source) or a microphone to the Input 1 jack or a line level signal to the Input 2 jack on the Auro X12D/X15D rear panel (figure 2). If using a microphone, set the Mic/Line Switch to the microphone position.
5. Connect the supplied power cable to the AC Power Inlet on the back of the loudspeaker. Plug the power cable into an AC outlet (figure 4).  
*Note: Always make sure that the AC outlet is configured with the correct voltage as indicated on the rear panel of the Auro loudspeaker.*
6. Switch the Auro's Power switch to the ON position.
7. Run an audio signal from your mixer, or talk into the microphone (figure 4).
8. Slowly raise the Auro's Level control until you have reached the desired level.
9. If the volume from the speakers gets really loud, or you see the Peak indicator blinking frequently, turn down the Level control on the Auro X12D/X15D a little until the Peak indicator does not light, or only lights occasionally with signal peaks.

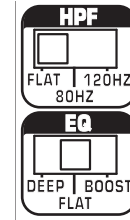

figure 1

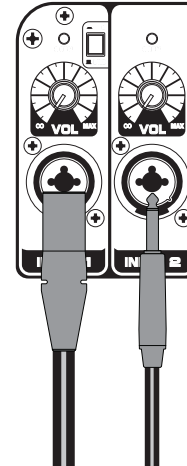

figure 2

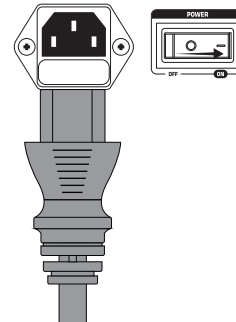

figure 3

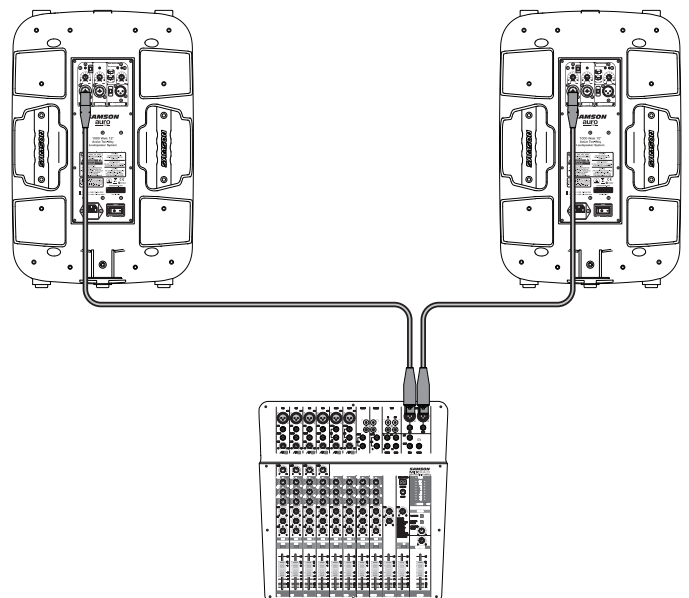
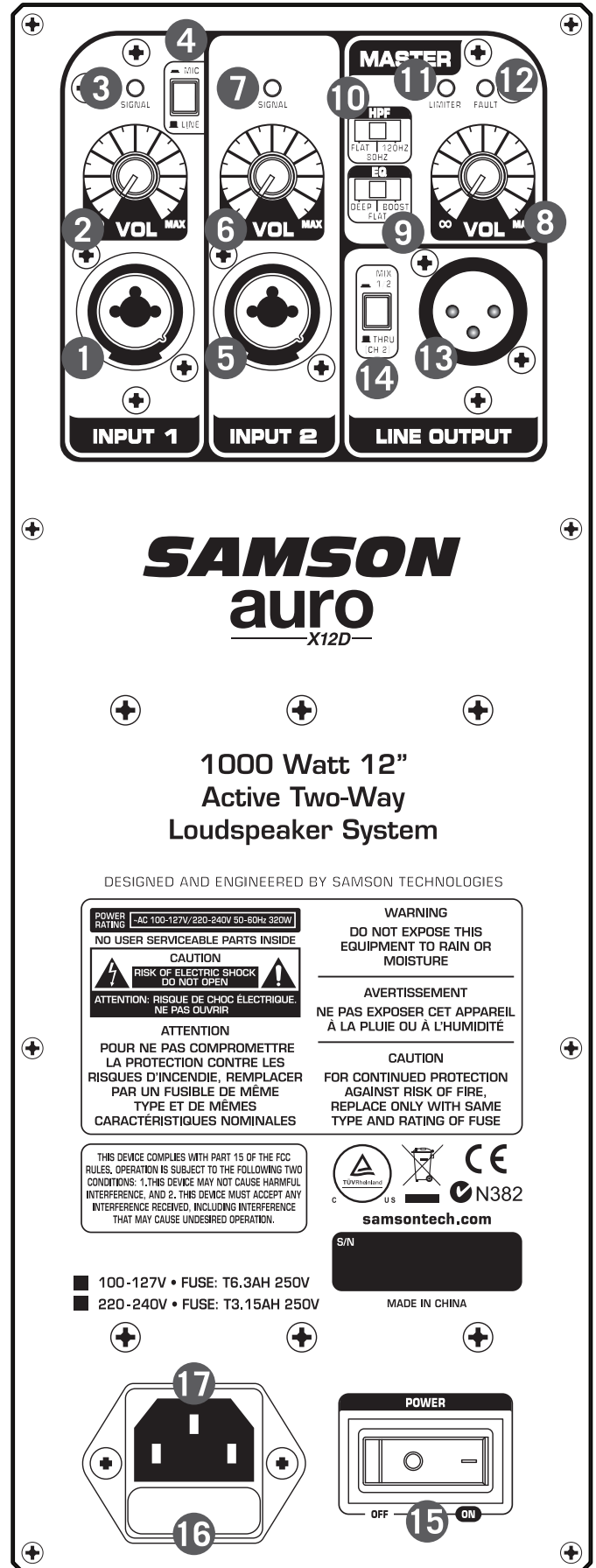

figure 4



# Rear Panel Layout

- 1. XLR and 1/4" Input Connector (Input 1)** - This combo XLR and 1/4" connector accepts either a balanced or unbalanced microphone or line level signal. The 1/4" phone input accepts TS or TRS type connectors.
- 2. VOL Control (Input 1)** - This Volume knob adjusts the level of the Input 1 channel.
- 3. SIGNAL Indicator (Input 1)** - This GREEN LED indicator, when illuminated, indicates that the signal is present at the Input 1, regardless of the Input 1 VOL Control setting.
- 4. Mic/Line Switch (Input 1)** - The MIC position changes the gain of Input 1 jacks to MIC level. The LINE position reduces the gain of both jacks by 30dB to line level.
- 5. XLR and 1/4" Input Connector (Input 2)** - This combo XLR and 1/4" connector accepts either a balanced or unbalanced line level signal. The 1/4" phone input accepts TS or TRS type connectors.
- 6. VOL Control (Input 2)** - This control adjusts the level of the Input 2 channel.
- 7. SIGNAL Indicator (Input 2)** - This GREEN LED indicator, when illuminated, indicates that the signal is present at the Input 2, regardless of the Input 2 VOL Control setting.
- 8. Master VOL Control** - This control adjusts the overall signal level at the input of the power amplifiers.
- 9. EQ Switch** - The Auro DSP has three EQ contour curves: NORMAL, DEEP, and BOOST. The NORMAL setting produces the standard frequency response and works best for most applications. The BOOST setting provides a high frequency lift for vocal clarity. This is useful when plugging a microphone directly into the speaker. The DEEP setting enhances low frequencies to add punch and high frequencies to add vocal clarity.



## Rear Panel Layout

10. **HPF Switch** - This switch adjust the High Pass Filter frequency of the cabinet. When using the Auro speaker with a subwoofer, set the switch to 80Hz or 120Hz depending on the specification of the subwoofer. It is also recommended to set the HPF to 120Hz when using the Auro speaker as a floor monitor to limit the low frequency build up on the stage.
11. **LIMITER Indicator** - This YELLOW LED lights when the amp is near the clipping point and the limiter is engaged. If the LIMITER indicator lights frequently, turn down the Master VOL control or INPUT VOL controls on the Auro speaker or turn down the signal at the source, until the indicator does not light anymore, or lights only occasionally with high signal peaks.
12. **Line Output** - Male XLR connector used to link multiple Auro cabinets.
13. **MIX 1/2 & THRU Switch** - This switch is used to select the signal that is sent to the Line Output. When the switch is in the up (MIX 1/2) position, the signal on the Line Output is a mix of both the Input 1 and Input 2 signals. When the switch is in the down (THRU) position the Line Output carries only the Input 2 signal.
14. **FAULT Indicator** - This LED lights RED when the input is overloaded, amp overheats or other problems have been detected. If the FAULT indicator lights due to the the amp overheating, the amplifier will limit the audio and lower the output level. Turn the volume controls down until the FAULT indicator is no longer lit. When the unit cools, the amplifier will raise the level back up.
15. **Power Switch** - This rocker switch turns on and off the Auro's main power. The switch lights RED when the amp is active.  
*NOTE: It is important to remember the Golden Rule of audio... "LAST ON, FIRST OFF."  
Translated, this means that when turning on your system, you should always turn your powered speakers on LAST, and when turning your system off, turn your powered speakers off FIRST. This helps avoid any loud pops caused by rush current at power up, or down, which can sometimes damage loudspeakers.*
16. **Fuse Cover** - The fuse is located behind the fuse cover. Always replace fuses with the same type of fuse.
17. **AC Power Inlet** - Connect the supplied standard 3-prong IEC power cable here.  
Note: Never disconnect the plug's ground pin. It is dangerous and can result in electric shock!

# Making Connections

## Using a Microphone

- Be sure that the Auro X12D/X15D Power switch is set to the off position.
- Turn the LEVEL control fully counterclockwise to the off position.
- Connect the power cable to an AC socket.
- Using a standard XLR cable, plug a microphone into the Auro's XLR INPUT 1.
- Set the MIC/LINE switch to the MIC (down) position.
- Set the MIX 1/2 & THRU switch to the MIX 1/2 position.
- Switch the Power switch to the ON position.
- While speaking or singing into the microphone, slowly raise the LEVEL control until you have reached the desired level.
- For larger sound reinforcement you can run several monitors using the Line Output to daisy-chain one Auro to another.

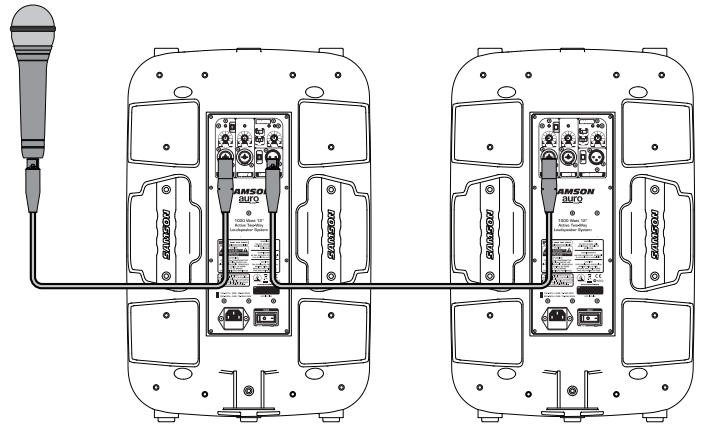

## Using a Stereo Line Level Signal

- Be sure that the Auro X12D/X15D Power switch is set to the off position.
- Turn the LEVEL control fully counterclockwise to the off position.
- Connect the power cable to an AC socket.
- Using standard XLR or 1/4" cables, connect the line level signals from a mixer or keyboard into the Auro Inputs.
- Switch the Power switch to the ON position.
- Now, run an audio signal from your mixer (like music from an MP3 player) while slowly raising the Auro's Level control until you have reached the desired level.

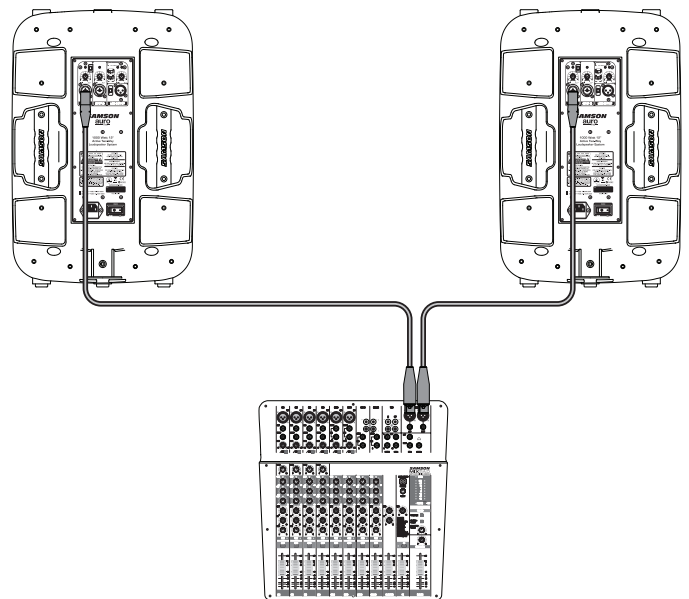

### Speaker Placement

Whenever possible, it is a good idea to raise the speakers above the heads of the listening audience. The Auro enclosures feature standard 1 3/8" pole mount receptacles with locking bolts, which are compatible with speaker stands from a variety of manufacturers. In a smaller setting like a school cafeteria, library, or a mall kiosk, you can also use the Auro loudspeaker in one of the tilt back monitor positions, which will improve the projection of the speakers and may eliminate the need for speaker stands.

*Note: When using a speaker pole mount, be sure the pole is capable of supporting the weight of the Auro loudspeaker.*

*Note: Always have another person to assist when mounting the Auro speaker onto a speaker stand, or when adjusting the stand while the speaker is mounted on the stand.*



### Using the Auro X12D/X15D as a Floor Monitor

The Auro X12D/X15D is an ideal solution for stage monitoring and thanks to its unique design, two wedge monitor positions are possible. When placed on its side, with the high frequency horn facing to the left of the enclosure, the Auro is tilted at a 30 degree angle, optimizing performance when used on a large stage. When placed on its side with the high frequency horn facing to the right of the enclosure, the Auro is tilted at a 45 degree angle optimizing performance when used on smaller stages.

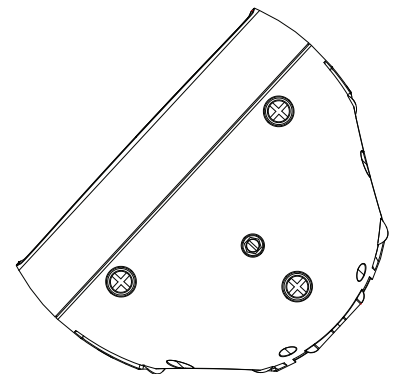

# Cables and Connectors

The Auro X12D/X15D features balanced inputs and outputs, so connecting balanced and unbalanced signals is acceptable. Whenever possible, use balanced connections to other equipment to suppress interference.

## Unbalanced 1/4" Connector

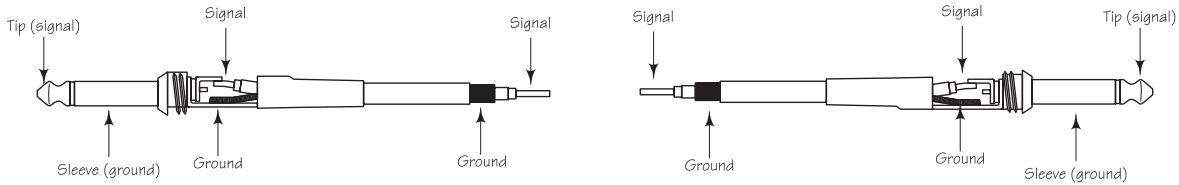

## Balanced TRS 1/4" Connector

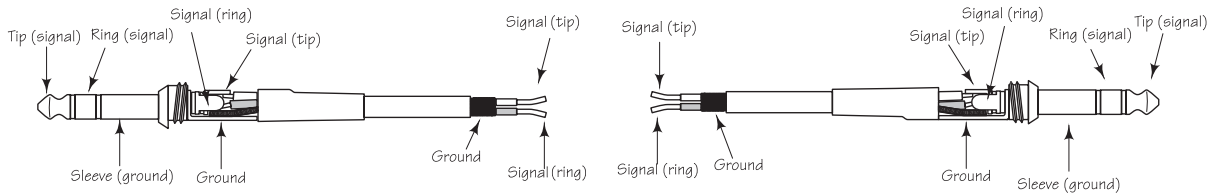

## XLR to XLR Balanced

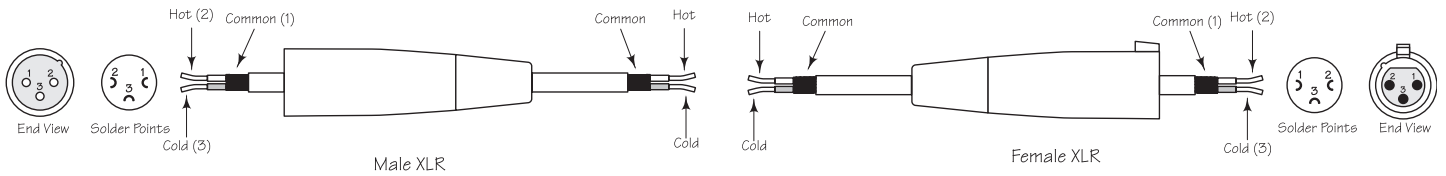

## Unbalanced 1/4" Connector to RCA

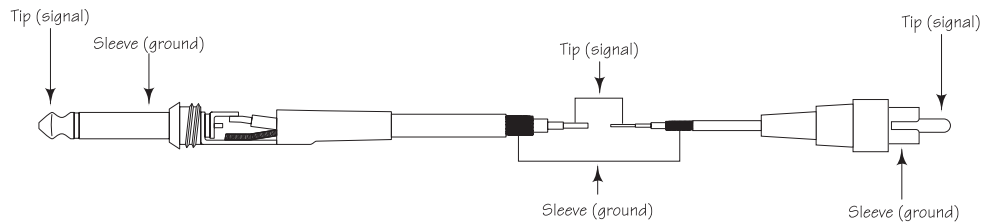

## XLR to Balanced 1/4-Inch

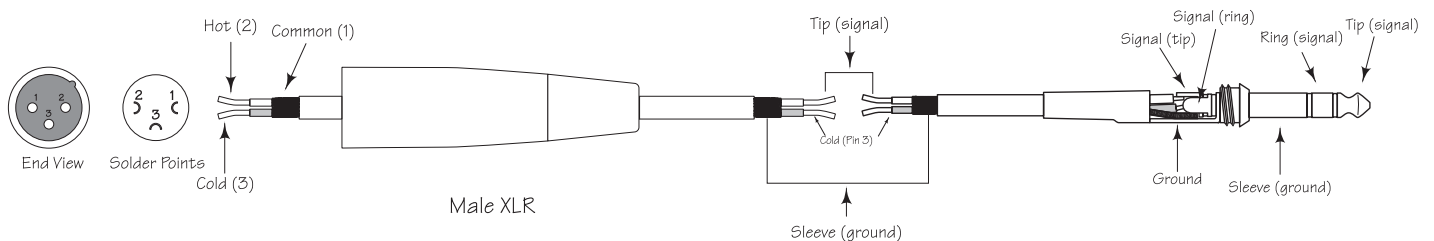

# Specifications

		X12D	X15D
<b>Output Power</b>			
Low Frequency	RMS Power	400 W @ 8 ohms	
	Peak Power	800 W @ 8 ohms	
	THD	< 1 %	
High Frequency	RMS Power	100 W @ 8 ohms	
	Peak Power	200 W @ 8 ohms	
	THD	< 1 %	
<b>Transducers</b>			
Low Frequency	12" bass transducer, 2.5" voice coil		15" bass transducer, 3" voice coil
High Frequency	1.34" (34 mm) titanium compression driver, edge-wound copper voice coil		
<b>Acoustic Performance</b>			
Frequency Response (-3 dB)	58 Hz to 20 kHz		55 Hz to 20 kHz
Maximum SPL (Peak Power)	125 dB SPL @ 1 m		125 dB SPL @ 1 m
Horizontal Coverage Angle	90°		
Vertical Coverage Angle	60°		
<b>Electronic Crossover</b>			
Crossover Type	24 dB/oct Linkwitz-Riley		
Crossover Frequency	2.3 kHz		2.1 kHz
<b>Input/Output</b>			
Inputs	Balanced XLR & ¼" Connectors (Input 1 Mic/Line Level; Input 2 Line Level)		
Output	Balanced XLR Line Output		
<b>Equalization Switches</b>			
HPF	Flat, 80Hz, 120Hz		
EQ	Flat, Deep, Boost		
<b>Power Supply</b>			
Power Consumption	456 W max.		
AC Connector	3-pin IEC 250 VAC, 20 A male		
Fuse	100 - 127 VAC T6.3AH / 250 V		
	220 - 240 VAC T3.15AH / 250 V		
<b>Dimensions and Weight</b>			
Dimensions	in	14" L x 10.8" W x 21.5" H	17.75" L x 13.5" W x 27.5" H
	mm	356 mm L x 275 mm W x 546 mm H	450 mm L x 342 mm W x 698 mm H
Weight	lbs	28.5	41.5
	kg	12.8	19
<b>Mounting</b>			
Mounting Method	Integral 1 3/8" Pole Mount Receptacle		
Fly Point	1 x M10		

*At Samson, we are continually improving our products, therefore specifications and images are subject to change without notice.*



# Dimensions

## X12D

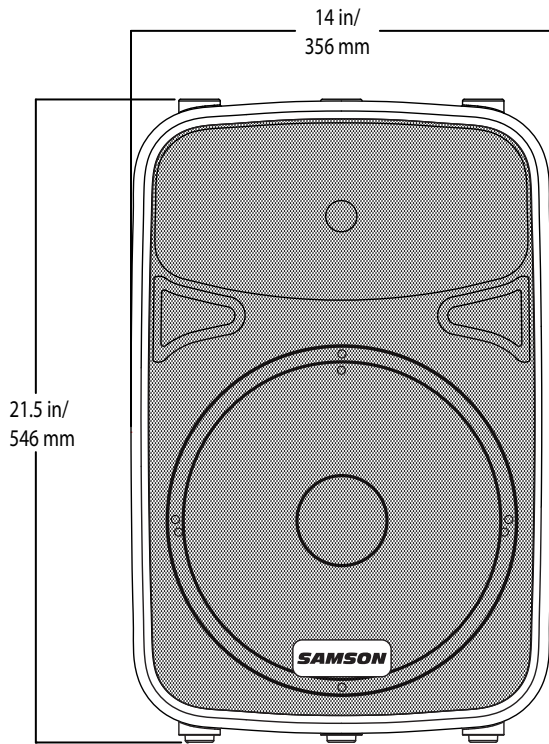
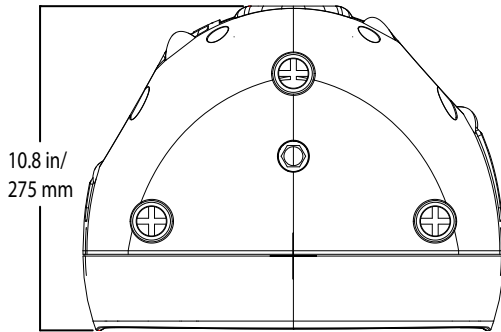

## X15D

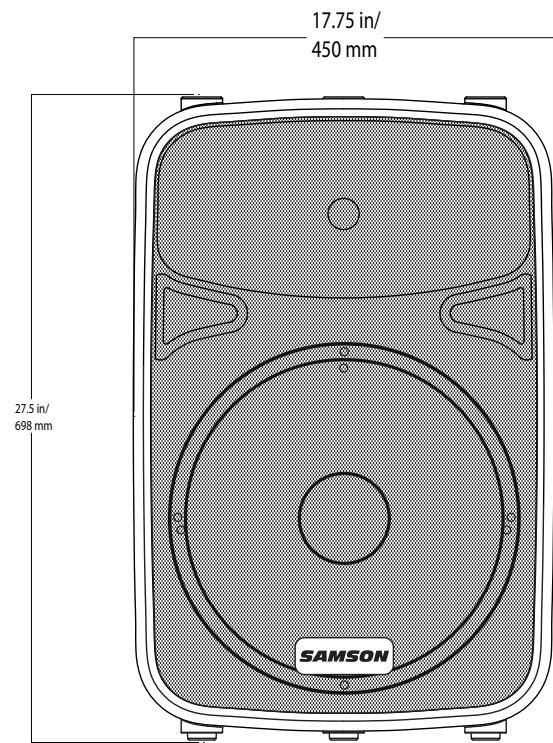
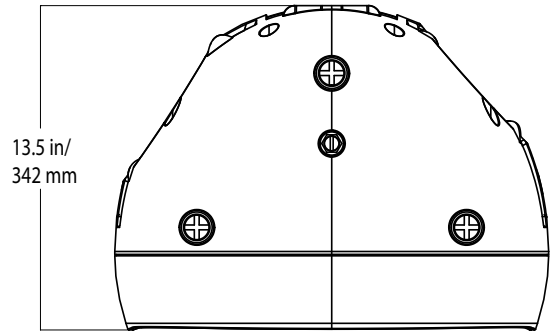

Samson Technologies Corp.  
45 Gilpin Avenue  
Hauppauge, New York 11788-8816  
Phone: 1-800-3-SAMSON (1-800-372-6766)  
Fax: 631-784-2201  
[samsontech.com](http://samsontech.com)