

# WA 120



## ULTRA PORTABLE WIRELESS PA

Nady wireless systems are type accepted under FCC rules parts 90, 74 and 15.

This device complies with RSS-210 of Industry & Science Canada. Operation is subject to the following two conditions: (1) this device may not cause harmful interference and (2) this device must accept any interference received, including interference that may cause undesired operation.



**NADY SYSTEMS, INC.**  
Emeryville, CA, USA  
[www.nadywireless.com](http://www.nadywireless.com)

## CONTENTS

INTRODUCTION .....	2
CONTROLS AND CONNECTIONS .....	3
OPERATING INSTRUCTIONS FOR THE NADY WA 120 .....	5
WA 120 WIRELESS MICROPHONE RECEIVER OPERATION .....	8
NADY WH-120 HANDHELD MICROPHONE TRANSMITTER .....	9
NADY WL-120 LAVALIER/HEADMIC BODYPACK TRANSMITTER .....	9
SPECIFICATIONS .....	12
SERVICE .....	12

## INTRODUCTION

Thank you for purchasing a Nady WA 120 Wireless Portable P.A.—and congratulations on your choice. The WA 120 is the most affordable and compact of the popular line of Nady wireless P.A.'s. Ideal for many applications, including use in classrooms, conference/meeting rooms, churches, health clubs and small auditoriums, it is powerful, yet lightweight and easily portable. We are sure you will find this versatile system a powerful and useful tool for your presentations.

The Nady WA 120 includes a full-range speaker system with built-in amplifier, mixer, and high band VHF wireless receiver. Special features include:

- Wireless system features Tone Squelch coding to eliminate external interference and noise reduction companding circuitry for quietest operation with a wide dynamic range.
- Available with choice of WH-120 handheld mic or WL-120 lavalier/headset mic bodypack transmitters. One WA 120 wireless P.A. and one WH-120 or WL-120 Transmitter on the same channel comprise a system.
- Powerful 20W audio output
- Three 1/4" unbalanced input jacks (2 MIC, 1 AUX) and one 1/4" unbalanced RECORD OUT, treble and bass controls
- External AC, DC (12-15V) or internal battery powered (8 X "D" alkaline or rechargeable batteries)
- Convenient internal charging ports for 2 X AA and one 9V rechargeable transmitter batteries (NiCad or Ni-MH)
- Small and lightweight—only 8.3" X 10.6" X 5.4" (211 X 270 X 137mm) and 6.3 lbs. (2.86 Kg)

## CONTROLS AND CONNECTIONS

1. **Wireless mic receiver antenna** Pull out and extend fully for optimum range
2. **Power ON/OFF switch**
3. **Signal input jacks**
4. **Speaker**
5. **Power ON LED indicator**
6. **RF ON LED indicator** Indicates reception of transmitter signal
7. **Volume controls**
8. **Tone controls**
9. **Record out jack** Provides signal for recording or additional amplification

10. **Battery charging LED indicators** Indicates internal charging mode for 2X AA and/or 9V rechargeable transmitter batteries
11. **Wireless mic receiver module**
12. **Battery charger for 2 X "AA" rechargeable transmitter batteries**
13. **Battery charger for one 9V rechargeable transmitter battery**
14. **AC power cord storage**
15. **AC fuse**
16. **Mounting hole for use with optional stand**
17. **AC power cord**
18. **Battery mount for 8 X "D" batteries** Used for internal battery operation of unit
19. **External DC input jack**
20. **Electrical specifications label**
21. **RF mute threshold (squelch) adjust**

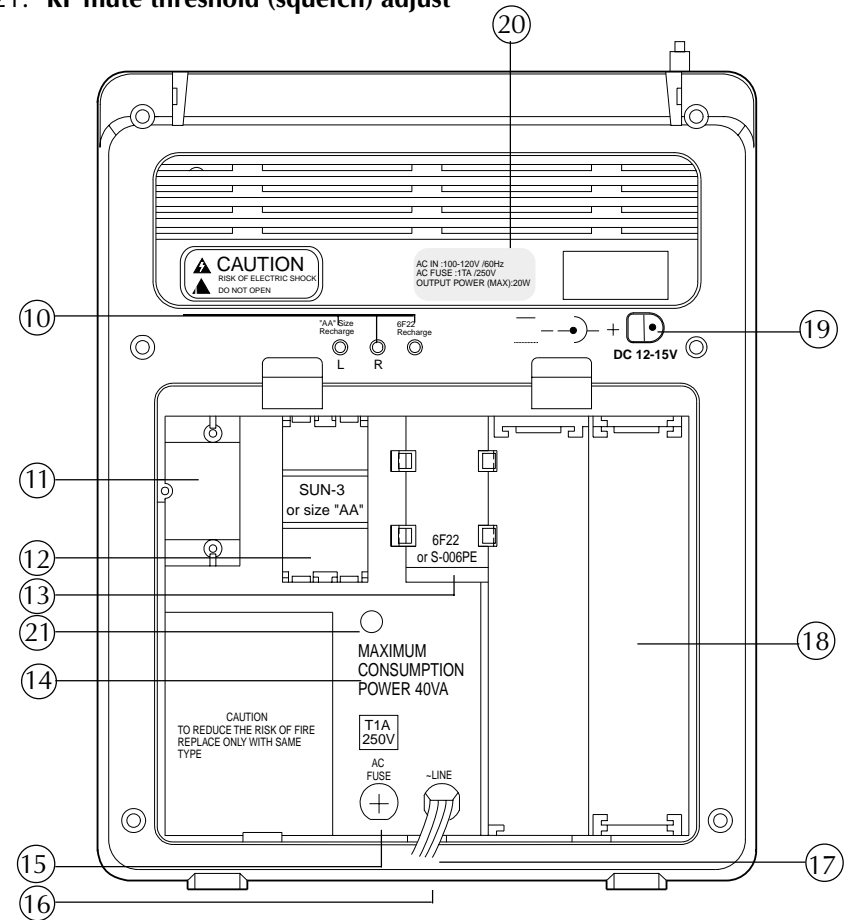
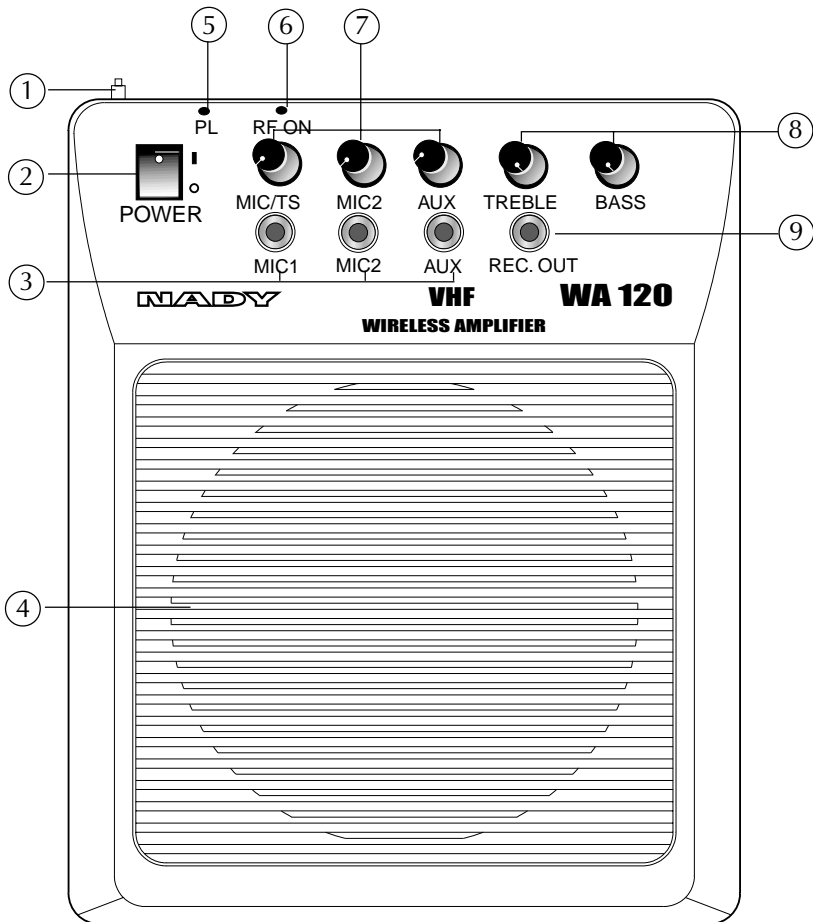

## OPERATING INSTRUCTIONS FOR THE NADY WA 120

### Powering the WA 120

- **AC power (17):** Plug the AC cord into an AC power socket (*Note: Before connecting to AC power, make sure the working voltage of your WA 120 either 115V AC or 230 V AC, as supplied and indicated on your unit (20) correctly matches your local AC power.*)

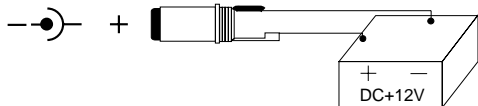

- **External DC power (19):** The WA 120 may also be DC powered using a 12-15V DC power supply plugged into the DC input jack (19). (*Note: To avoid damaging your unit's power supply electronics, make sure that the DC input has the correct polarity: negative center conductor and positive sleeve*)

**Attention: The DC input jack (19) will automatically switch between external DC or the internal battery pack (8 X "D" cells). Inserting the external DC plug will automatically disconnect the internal DC power. This prevents damage to the internal batteries.**

- **Internal power (18):** The WA 120 can also be powered by the internal 8"D" batteries. (*Note: Insert the batteries with correct polarity as marked. For longest operation, use only alkaline batteries.*) Replace the batteries when the output volume drops or the range of the wireless shortens.

### Operation

Before switching on the unit, make sure that the volume controls (7) are off or at minimum levels and that both of the tone controls (8) are in the center position. This will prevent possible loud noises or damage to the speaker when the unit is turned on. Switch (2) on the unit. The power ON indicator (5) will light red to show that the system is on. After the signals are input and/or the wireless mic is turned on, adjust the volume (7) and tone controls (8) as desired

### Attention:

1. If feedback (howling sound) occurs, try first turning down the treble control (8). If feedback still is present, try turning down the volume (7) or repositioning the WA 120 with respect to the wired or wireless mic being used.
2. Extend the antenna (1) fully whenever using the wireless microphone to ensure optimum performance and maximum range.
3. When a wired microphone is connected to the MIC 1 input jack (3), the wireless mic output will automatically be cut off.

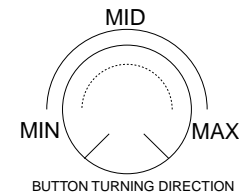

### Wiring Illustration

The AUX input (3) can be connected to a cassette or CD player or other such sound source.

The REC OUT (9) can be connected to a recording device or to the input jack of a power amplifier to further amplify and enlarge the audio power. For stereo to mono conversion of the signals, wire the connecting cord as per the the following illustration:

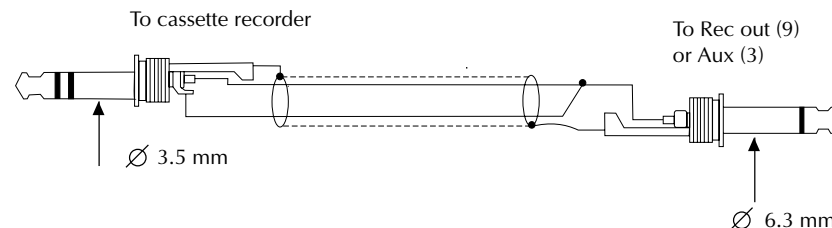

## Transmitter Battery Charging Operation

The WA 120 has two charging ports in the rear compartment for charging both 2 "AA" batteries (12) and a single 9V (13). These battery chargers can be used whenever the WA 120 is operated from AC power. If you are using rechargeables in your transmitter you can replace them as necessary with freshly charged ones, even during use. The discharged battery can immediately be put on charge. The charging LED indicator (10) will light whenever a battery is taking a charge. When the battery is fully charged, the indicator will turn off.

**Attention: These battery chargers (12) (13) can only be used for NiCad or Ni-MH rechargeables. Never use them for any other type of battery under any circumstance as this can result in damage to your unit and even danger from exploding batteries.**

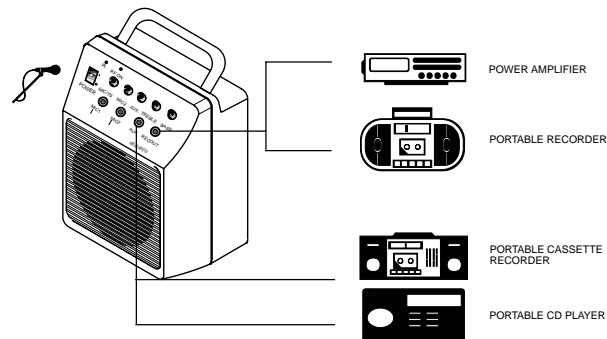

## Stand Mounting the WA 120

The WA 120 can be mounted on the optional ST-2 stand for convenient placement in a higher position. Contact your dealer or the Nady service department. (See Page 12)

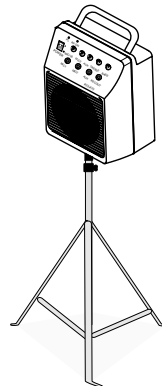

## WA 120 WIRELESS MICROPHONE RECEIVER OPERATION

The WA 120 contains a built-in high quality quartz-locked, fixed frequency VHF wireless receiver precisely matched to the Nady WH-120 or WL-120 transmitter supplied; therefore no adjustments besides audio volume are required.

- After the amplifier has been turned on by the main power switch (2), turn the wireless receiver's MIC/TS volume control (7) slightly clockwise.
- Switch on the wireless microphone and the RF receiving indicator (6) will light up indicating normal reception.
- Adjust the MIC/TS volume control (7) clockwise for the desired audio level.

*Note: If using more than one wireless microphone (handheld and/or bodypack) on the same frequency, switch only one on at a time. Microphones on the same frequency will interfere with each other. However, one wireless microphone can be used with two or more WA 120 wireless amplifiers with the same frequency simultaneously to increase the overall sound level.*

## WH-120 Handheld Microphone Transmitter

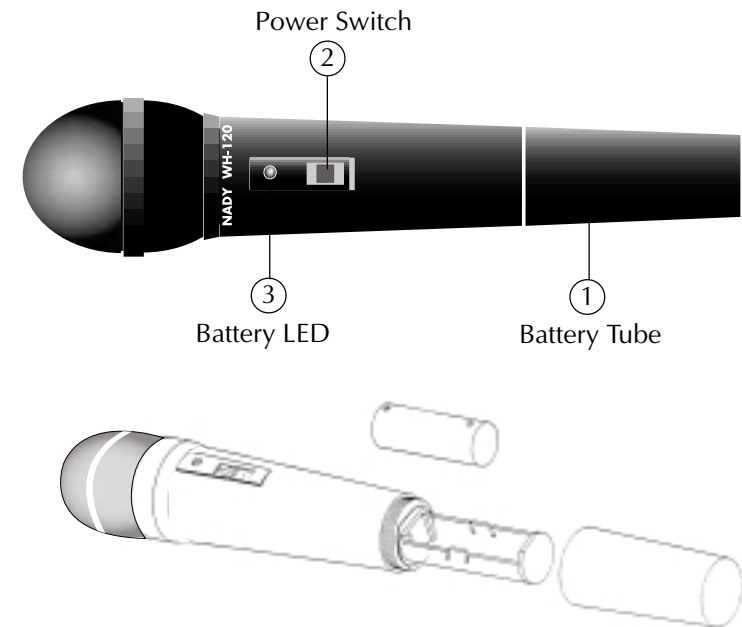

## NADY WH-120 HANDHELD MICROPHONE TRANSMITTER

The Nady WH-120 is a sleek tapered microphone with these special features:

- The Nady DM-10D custom mic element delivers top audio performance, with low handling noise and excellent feedback immunity
- Compact rugged housing with integral antenna—no dangling wires or protruding antenna
- Low battery LED indicator
- Unique screw-on battery compartment for quick pop-in battery replacement. Over 12 hours of continuous operation with a single AA battery.

### Transmitter Set-up and Operation

- Unscrew the battery compartment cover end cap (1) and remove, exposing the battery compartment. Insert a fresh AA battery, observing polarity.
- Turn on the microphone power switch (2) on the handle of the microphone. The battery indicator LED (3) will give a single quick flash, indicating usable battery strength. In the case of a dead or low battery, the indicator will either not go on at all or will stay on continuously, indicating a need to replace the battery. To preserve battery life, turn the transmitter off when not in use.
- The RF ON indicator on the WA 120 should now be lit.
- Adjust the volume of the WA 120 to the desired level.

## NADY WL-120 LAVALIER/ HEADMIC BODYPACK TRANSMITTER

The Nady WL-120 is a rugged compact bodypack designed for use with lavalier or headworn mics, and includes these special features:

- Easy access controls
- Audio cord acts as antenna—no extra antenna needed
- Easy access input level (volume) control for optimum adjustment
- Low battery LED indicator
- Input sensitivity select switch for easy switching between lavalier and headworn mics
- Powerful spring steel clip for secure mounting on user
- Unique locking plug holds mics securely to transmitter under any conditions
- Operates on 2 "AA" batteries for economical and long life operation.

## WL-120 Bodypack Transmitter

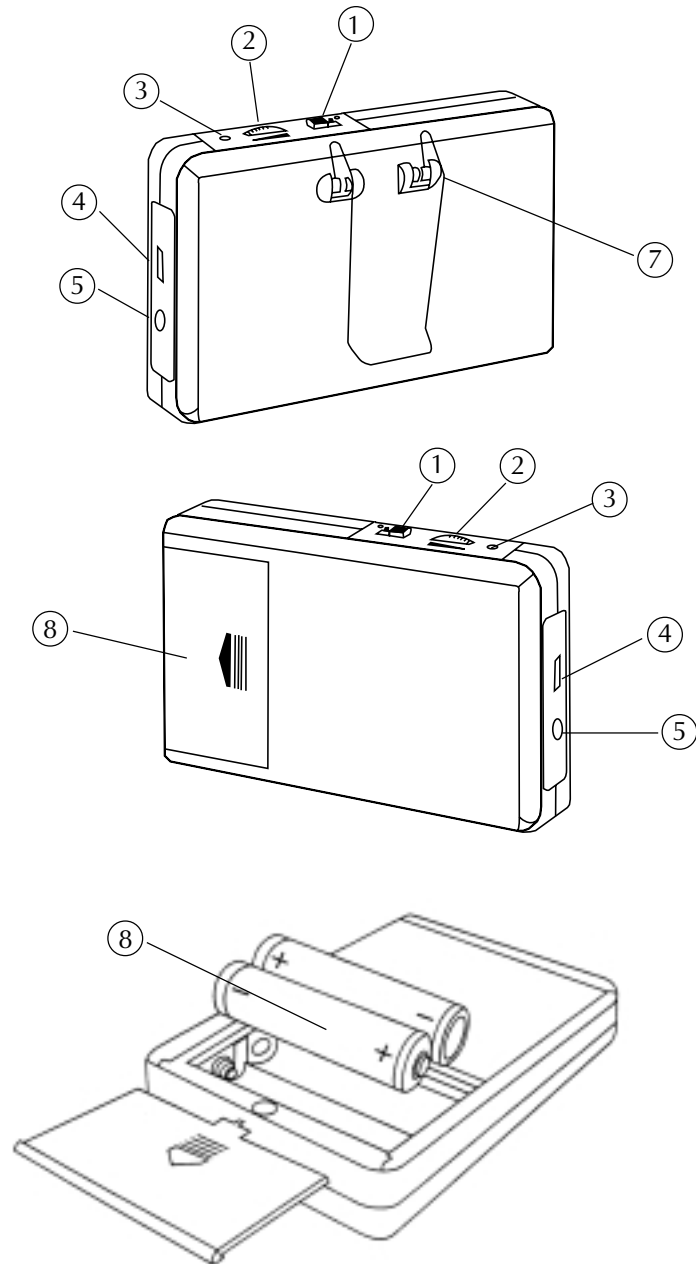

## Transmitter Set-up and Operation

- Install two fresh AA batteries in the battery compartment (8), observing correct polarity.
- Attach either the supplied LM-1 lavalier microphone or an optional headworn mic, such as a Nady HM Series Headmic™, to the transmitter. Note that the collar of the plug rotates in a clockwise direction, locking the plug onto the threaded mic jack (5). Depending on which mic you use, you must adjust the transmitter input sensitivity via the sensitivity switch (4). Select 1 for the LM-1 lavalier mic and 2 for the headworn mic.
- Turn on the transmitter by pushing the ON/OFF switch (1) to the ON position. The low battery indicator (3) will give a single quick flash. This indicates usable battery strength. In the case of a dead or low battery, the indicator either will not go on at all or will stay on continuously, indicating a low battery which must be replaced prior to operation. To preserve battery strength, turn the transmitter off when not in use.
- The RF ON light on the WA 120 should now be lit.
- Clip the transmitter to belt (7) or place in pocket. If using the lavalier microphone, place it at chest level. Do not place it too close to the mouth—a distance of about 6-8 inches works best. If using the headworn mic, experiment with the mic placement with respect to the mouth for optimum sound. Usually about one inch in front of the mouth and to the side yields the best sound.
- The audio wire to the mic is the transmit antenna, and rolling up or shortening the wire may reduce the effective operating range. Extend the wire fully during use, and keep it as straight as possible.
- Adjust the volume control of the WA 120 to a comfortable listening level as desired.
- If necessary, you can use the volume control (2) on the transmitter to adjust the input level for optimum sound. It should be set as high as possible without the audio distorting during use. If it does distort during loud peaks, just turn the volume control down slightly as necessary for clear audio even at the loudest input signal.

**Note:** *If using a lavalier microphone, please note there are two types, each with different characteristics and tradeoffs.*

**1) Unidirectional** – mic only picks up audio from the front so volume may vary as head is moved from side to side while talking. Susceptibility to feedback (speaker howling or screeching) is diminished due to the unidirectional pickup.

**2) Omni directional** – mic picks up audio equally from all directions so volume remains more level as head is moved about. Feedback is increased due to omnidirectional pickup.

## SPECIFICATIONS

<b>Audio Power Output:</b>	20W maximum, 4 ohms
<b>External AC Power:</b>	100~120VAC/60Hz or 200~240VAC/50 Hz (as supplied)
<b>AC Power consumption:</b>	40 VA
<b>External DC Power:</b>	12-15VDC (center conductor negative and sleeve positive), 1800 mA
<b>Fuse:</b>	1TA, 250V, 5 X 20mm glass type
<b>Internal Batteries:</b>	8 "D" size alkaline batteries (SUM-1)
<b>Input Sensitivity/</b>	<b>MIC 1/TS:</b> -52dB +/-2dB, 150-15KHz +/-3dB
<b>Frequency Response:</b>	<b>MIC 2:</b> -52dB +/-2dB, 150-15KHz +/-3dB
	<b>AUX:</b> -18dB +/-2dB, 100-15KHz +/-3dB
<b>T.H.D.:</b>	1%
<b>Inputs:</b>	One each wireless mic, hardwired mic and AUX line inputs
<b>Tone Control Range:</b>	<b>Treble:</b> +/-5dB at 10KHz
	<b>Bass:</b> +/-4dB at 200 Hz
<b>REC output level:</b>	280mV at 100 Kohms
<b>Charging current,</b>	
<b>"AA" battery charger:</b>	70-150mA (DC)
<b>9V battery charger:</b>	5-70mA (DC)
<b>Wireless Operating</b>	
<b>Frequency Range:</b>	170-216MHz, FM(3E)
<b>Wireless Operating</b>	
<b>Distance:</b>	100 ft. typical, up to 200 ft. line of sight
<b>Dimension:</b>	8.3" X 10.6" X 5.4" (211 X 270 X 137mm)
<b>Weight:</b>	6.3 lbs. (2.86 Kg.)

## SERVICE

(U.S.) Should your Nady WA-120 require service, please contact the Nady Service Department via phone at (510) 652-2411 or e-mail at [service@nadywireless.com](mailto:service@nadywireless.com) for a Return Authorization (R/A) number and a service quote (if out of warranty). Make sure the R/A number is clearly marked on the outside of the package, cashier's check or money order is enclosed (if not prepaid with a credit card), and ship the unit prepaid to: Nady Systems, Inc., Service Department, 6701 Shellmound Street, Emeryville, CA 94608. Include a brief description of the problems you are having.

(International) For service, please contact the Nady distributor in your country through the dealer from whom you purchased this product.

**DO NOT ATTEMPT TO SERVICE THIS UNIT YOURSELF AS IT CAN BE DANGEROUS AND ALSO VOID THE WARRANTY**