

PSM® 400 Wireless Personal Performance Pack

Featuring the P4M Mixer, P4T Transmitter and P4R Receiver

Ensemble personnel pour concert PSM 400

Comprend le mélangeur P4M, l'émetteur P4T et le récepteur P4R

PSM 400 individuelles Monitorsystem

Bestehend aus dem P4M-Mischer, P4T-Sender und P4R-Empfänger

Sistema personal PSM 400

Incluye una mezcladora P4M, un transmisor P4T y un receptor P4R

Sistema completo per uso individuale PSM 400

Comprende il mixer P4M, il trasmettitore P4T e il ricevitore P4R





**USING THIS SYSTEM AT EXCESSIVE VOLUMES CAN CAUSE PERMANENT HEARING DAMAGE.
USE AS LOW A VOLUME AS POSSIBLE.**

In order to use this system safely, avoid prolonged listening at excessive sound pressure levels. Please use the following guidelines established by the Occupational Safety Health Administration (OSHA) on maximum time exposure to sound pressure levels before hearing damage occurs.

90 dB SPL at 8 hours
95 dB SPL at 4 hours
100 dB SPL at 2 hours
105 dB SPL at 1 hour
110 dB SPL at 1/2 hour
115 dB SPL at 15 minutes

120 dB SPL — avoid or damage may occur

It is difficult to measure the exact Sound Pressure Levels (SPL) present at the eardrum in live applications. In addition to the volume setting on the PSM, the SPL in the ear is affected by ambient sound from floor wedges or other devices. The isolation provided by the fit of quality earphones is also an important factor in determining the SPL in the ear.

Here are some general tips to follow in the use of this product to protect your ears from damage:

1. Turn up the volume control only far enough to hear properly.
2. Ringing in the ears may indicate that the gain levels are too high. Try lowering the gain levels.
3. Have your ears checked by an audiologist on a regular basis. If you experience wax buildup in your ears, stop using the system until an audiologist has examined your ears.
4. Wipe the earphones with an antiseptic before and after use to avoid infections. Stop using the earphones if they are causing great discomfort or infection.



This symbol indicates that there are important operating and maintenance instructions in the literature accompanying this unit.

Licensing Information

Changes or modifications not expressly approved by Shure Incorporated could void your authority to operate the equipment. Licensing of Shure wireless microphone equipment is the user's responsibility, and licensability depends on the user's classification and application, and on the selected frequency. Shure strongly urges the user to contact the appropriate telecommunications authority concerning proper licensing, and before choosing and ordering frequencies.

THIS RADIO EQUIPMENT IS INTENDED FOR USE IN MUSICAL PROFESSIONAL ENTERTAINMENT AND SIMILAR APPLICATIONS.

NOTE: THIS EQUIPMENT MAY BE CAPABLE OF OPERATING ON SOME FREQUENCIES NOT AUTHORIZED IN YOUR REGION. PLEASE CONTACT YOUR NATIONAL AUTHORITY TO OBTAIN INFORMATION ON AUTHORIZED FREQUENCIES FOR WIRELESS MICROPHONE PRODUCTS IN YOUR REGION

Licensing: Note that a ministerial license to operate this equipment may be required in certain areas. Consult your national authority for possible requirements.

Shure Transmitter Model P4T may be used in the countries and frequency ranges listed in Table 1 on page 83.

TABLE OF CONTENTS

INTRODUCTION	5
PSM[®] 400 QUICK SET UP GUIDE	5
P4M MIXER	6
Controls and Features	6
Set-Up	6
Using the P4M Personal Monitor Mixer	7
P4T TRANSMITTER	8
Controls and Features	8
Set-Up	8
Loop Applications	9
P4R RECEIVER	10
Controls and Features	10
Battery Installation	10
Set-Up	10
Pushbutton Controls	10
LCD Screen	11
Locking Out the LCD Screen	11
MIXMODE[®]/STEREO CONTROL	12
SYSTEM APPLICATIONS	13
TROUBLESHOOTING	15
SPECIFICATIONS	16
RACK MOUNTING	18

INTRODUCTION

The PSM[®] 400 Wireless Personal Performance Pack

Thank you for buying the Shure PSM[®] 400 Wireless Personal Performance Pack, featuring the P4M Personal Monitor Mixer, the P4T Transmitter, the P4R Receiver and SCL3 earphones. Like all Shure PSM personal monitoring products, the PSM 400 provides the many advantages of a wireless, in-ear monitoring system, including:

- **Improved Sound Quality** – high fidelity without the risk of feedback,
- **Increased Mobility** – your mix moves with you,
- **Personal Control** – through volume adjustment and MixMode[®].

For information on this and other Shure products, visit www.shure.com on the World Wide Web.

PSM 400 Quick Set-Up Guide

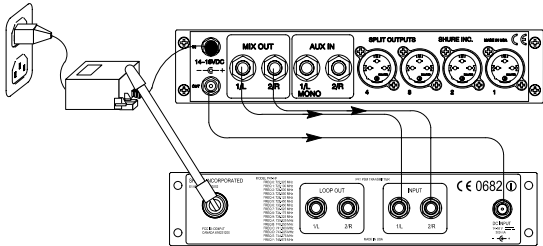

1. Plug in the PS40 power supply and connect it to mixer's DC IN connector. Connect mixer's DC OUT connector to transmitter's DC input.
2. Attach the antenna to the ANTENNA OUT BNC connector.
3. Connect mixer's 1/L and 2/R MIX OUT jacks to transmitter's 1/L and 2/R INPUT jacks.

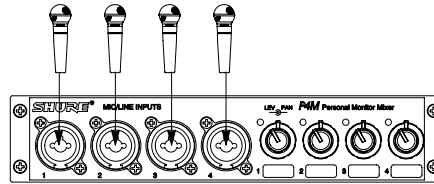

4. Connect audio sources to mixer's MIC/LINE INPUTS.
5. Mix audio sources using LEVEL/PAN knobs. Use outer ring to pan signal left or right, and use inner knob to adjust signal level.
6. Check signal/clip LEDs.

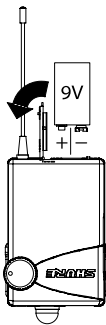

7. Insert battery into receiver.

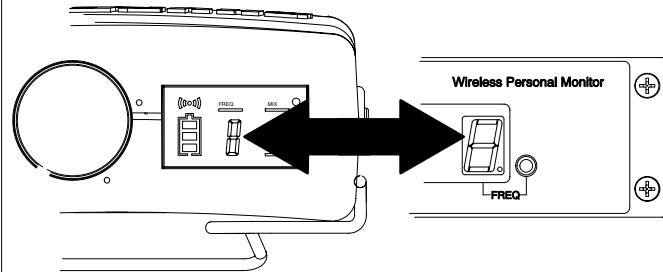

8. Turn receiver volume knob past click (ON). Keep volume at minimum.
9. Set receiver functions (see *P4R Receiver* on page 10).
10. Set transmitter and receiver to same frequency channel.

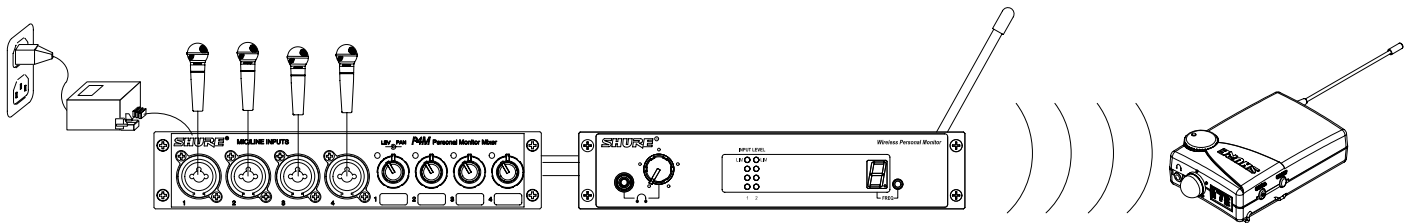

11. Check RF symbol on receiver LCD to confirm RF reception.
12. Insert earphones into earphone jack on the receiver. Insert earphones into your ears.
13. Slowly increase receiver volume to a comfortable level.

THE P4M MIXER

Controls and Features

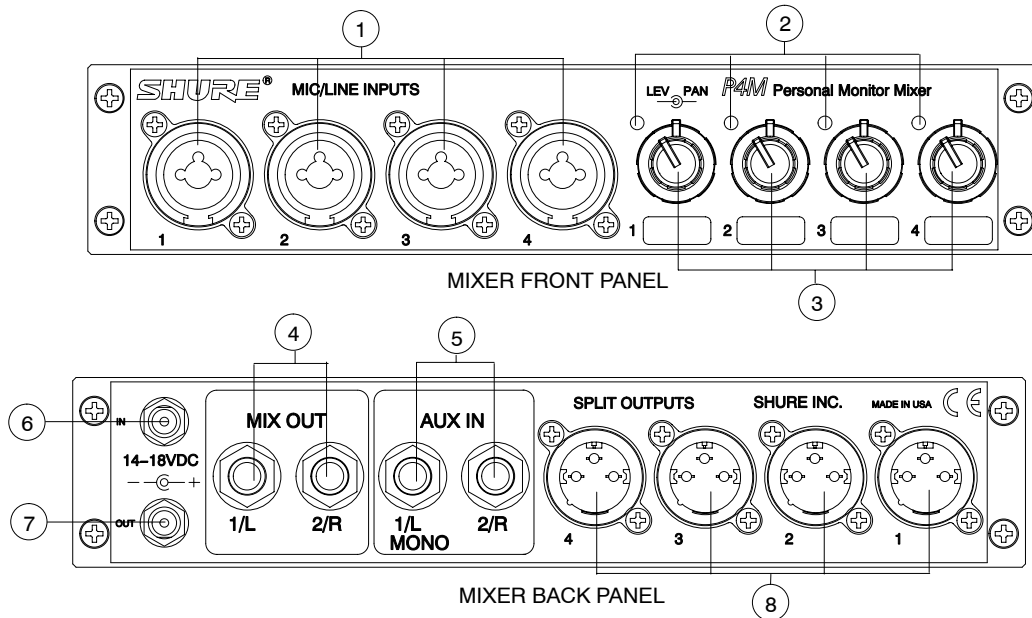

- MIC/LINE INPUT Jacks:** Accommodate both XLR and 1/4" connectors at mic or line levels. They are electronically balanced.
- Signal/Clip LEDs:** Color indicates the signal status of the corresponding mic/line input:

LED Color	Signal Status
Green	Signal present
Yellow	Nominal Level
Red	Signal clipping

- CONCENTRIC LEVEL/PAN Knobs:** The inner knob controls the input level; the outer ring pans the input signal between the 1/L and 2/R mix outputs.

- MIX OUT Output Jacks:** 1/4" TRS jacks provide the line level mix created with the level/pan knobs.
- AUX IN Inputs:** Signals from two 1/4" TRS input jacks are combined with the mix created by the level/pan knobs. Front panel settings do not affect these jacks.
- DC IN Locking Connector:** Plug the PS40 AC adaptor into this connector.
- DC OUT Locking Connector:** Powers a P4T transmitter or another P4M mixer. A DC jumper cable is provided with the mixer. **NOTE:** A PS40 can only power two Shure devices.
- SPLIT OUTPUTS:** Each male XLR output provides a duplicate of its corresponding mic/line input. Front panel settings have no effect on split outputs.

Set-Up

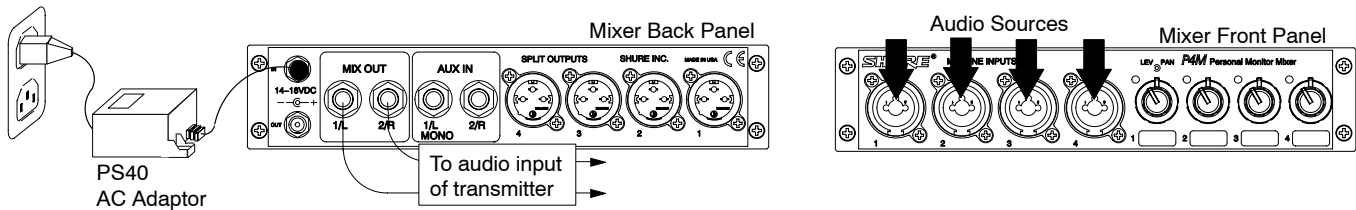

- Plug the PS40 AC adaptor into the mixer's DC IN locking connector. Plug the other end into a wall socket.
- Connect the MIX OUT jacks to the audio input of the P4T wireless transmitter.
- Connect up to four audio sources (microphones, instruments, mixers) into the input jacks on the front panel of the mixer.

Using the P4M Personal Monitor Mixer

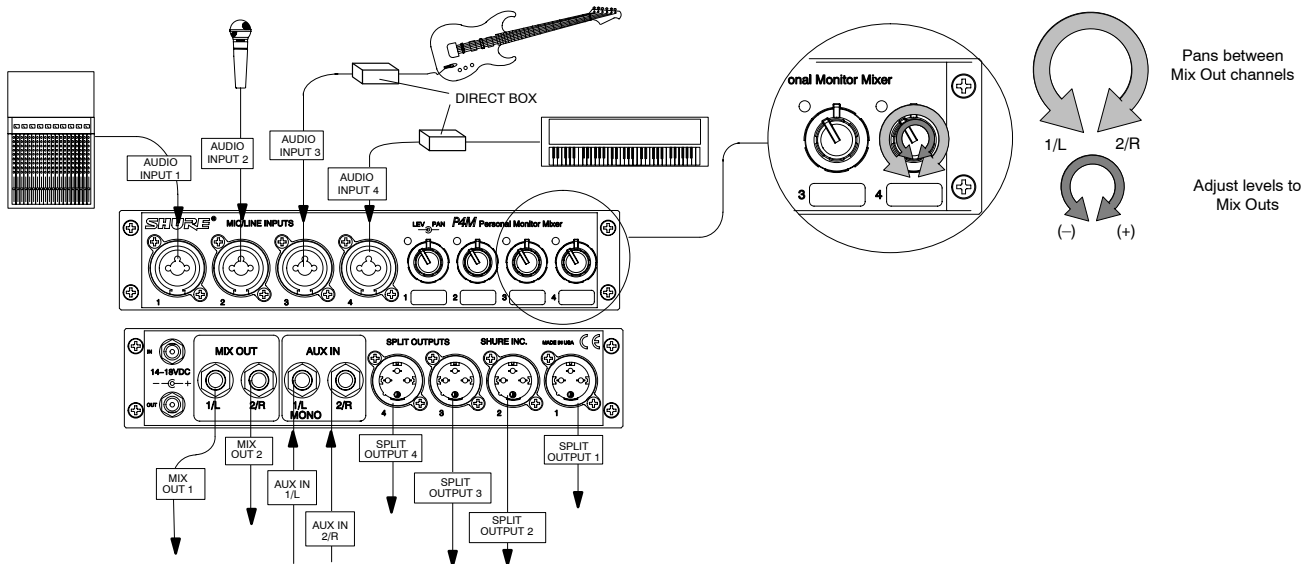

Once the basic set up is complete, use the P4M Personal Monitor Mixer to create a custom mix:

1. Mix the signal from each audio input using the corresponding CONCENTRIC LEVEL/PAN knob:
 - OUTER RING: Use this to pan the signal to the left or right channel of the stereo mix.
 - INNER KNOB: Use this to control the level of the audio input.
2. Observe the signal/clip LEDs next to each CONCENTRIC LEVEL/PAN knob.

NOTE: Decrease the level of an input if the corresponding signal/clip LED is consistently red. If the level is decreased all the way and the LED remains red, the level of the input from the previous device in the audio chain is too high and should be decreased.
3. Up to two additional line-level audio sources (such as other mixers, a click track or a digital sequencer) may be added via the AUX IN inputs. These signals go directly to the MIX OUT outputs and are not affected by the CONCENTRIC LEVEL/PAN knobs.
4. To pass an unaltered signal through the mixer, use the corresponding SPLIT OUTPUT.

NOTE: Although the mixer does not provide phantom power for condenser microphones, the SPLIT OUTPUTS can pass phantom power from a phantom power supply to a microphone connected to the corresponding input jack.

CAUTION!: Use a “direct box” when connecting guitars, keyboards, and other instruments to a mixing console through the P4M Mixer. The phantom power that mixing consoles provide for microphones can damage other instruments. Connect the instrument to the direct box then connect the direct box to the P4M Mixer input.

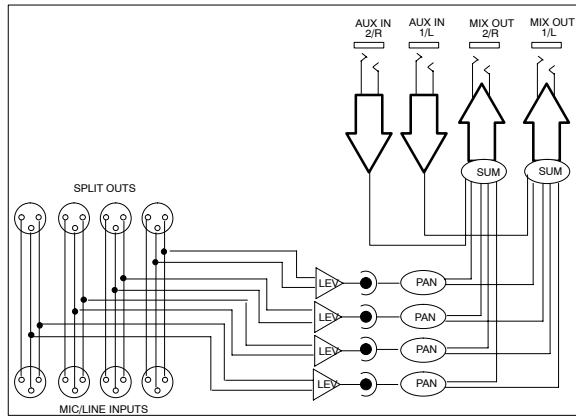

Audio signal path for the P4M Mixer

THE P4T TRANSMITTER

Controls and Features

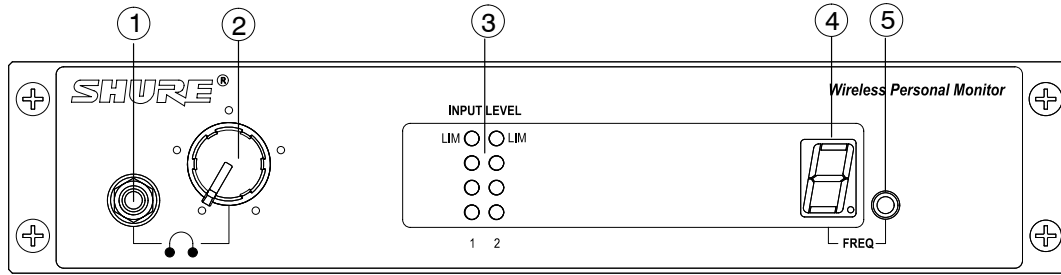

TRANSMITTER FRONT PANEL

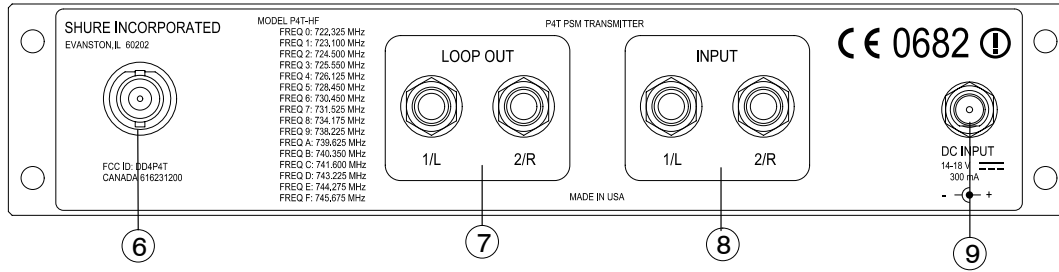

TRANSMITTER BACK PANEL

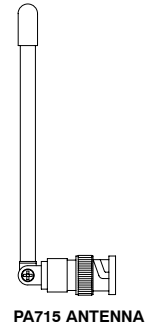

1. **Local Earphone Output Jack (1/8 inch):** Connects to earphones.
2. **Local Earphone Level Control:** Adjusts the volume of the local earphone jack's amplifier. Always listen at low levels.
3. **Input Level LEDs:** Two vertical strings of four LEDs display the input level of the left and right input channels. The four LEDs on the left display the status of the signal from channel 1 and the four LEDs on the right display the status of the signal from channel 2:

LED	Signal Status
RED (top)	Limiter Active
YELLOW (middle)	Nominal Level
GREEN (bottom two)	Signal Present

4. **Transmission Frequency LED:** This indicates which of the 16 Channels (0–9 or A–F) is transmitting.
5. **Frequency Select Button:** This recessed button changes the transmission channel. (Use a 1/4" plug to press this button.)
6. **Antenna Connector 50 Ω, BNC type:** This connects to the antenna to transmit UHF signals to the receiver.
7. **LOOP OUT Jacks:** Two 1/4" TRS jacks allow the audio signal to pass through the transmitter to other devices, including other transmitters, tape recorders, or amplifiers. See *LOOP Applications* on page 9.
8. **Input Jacks:** Two 1/4" TRS switching jacks are line level audio inputs.
9. **DC Input Connector:** Input for PS40 power supply or P4M mixer's DC jumper cable.

Set-Up

Follow these directions to set up the P4T transmitter for operation:

1. Plug the mixer's DC OUT jumper cable into the transmitter's DC input.
2. Attach the antenna to the ANTENNA OUT BNC connector.
3. Connect the mixer's MIX OUT 1/L and MIX OUT 2/R to inputs 1/L and 2/R of the transmitter.
4. Select an operating frequency using the FREQUENCY SELECT button. Push the button repeatedly until the LED displays the desired channel. The display will flash. Push and hold the button until the flashing stops to confirm the change (use a 1/4" plug to press the button).

IMPORTANT: Never set more than ONE transmitter to the same operating frequency.

5. Once the transmitter transmits audio, observe the INPUT LEVEL LEDs. If the LEDs consistently illuminate red, decrease the output level of the audio source until the red LEDs only flicker occasionally.
6. Set up the P4R receiver as directed in the P4R section of this user's guide. Make sure that the frequency selected on the receiver matches the frequency selected on the transmitter.

Loop Applications

The LOOP OUT 1/L and 2/R outputs allow the signal going through the P4T transmitter to be routed to other devices. The LOOP feature of the transmitter can be used for any number of applications. Shown here are only a few examples of how it can be used. Also see *System Application #3*.

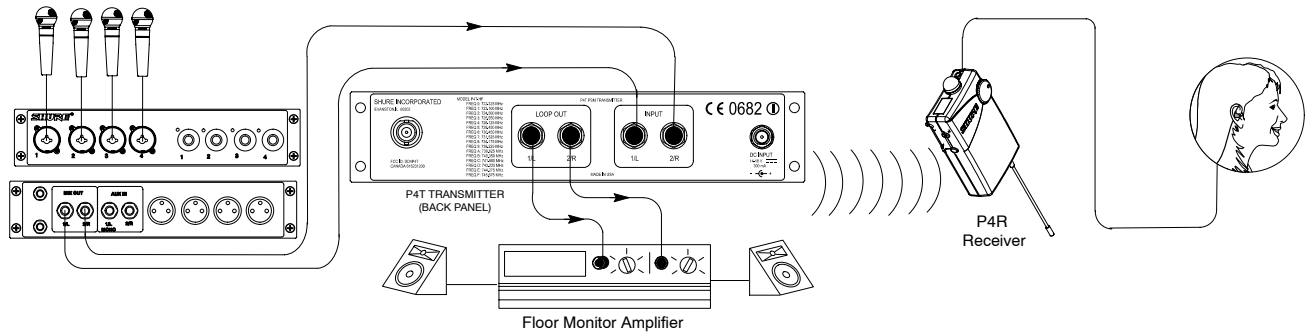

Running Floor Monitors Through a P4T Transmitter: An audio signal can be sent through the LOOP connectors to an amplifier for an onstage monitor system. When setup this way, the P4R and the onstage monitors will reproduce the same audio.

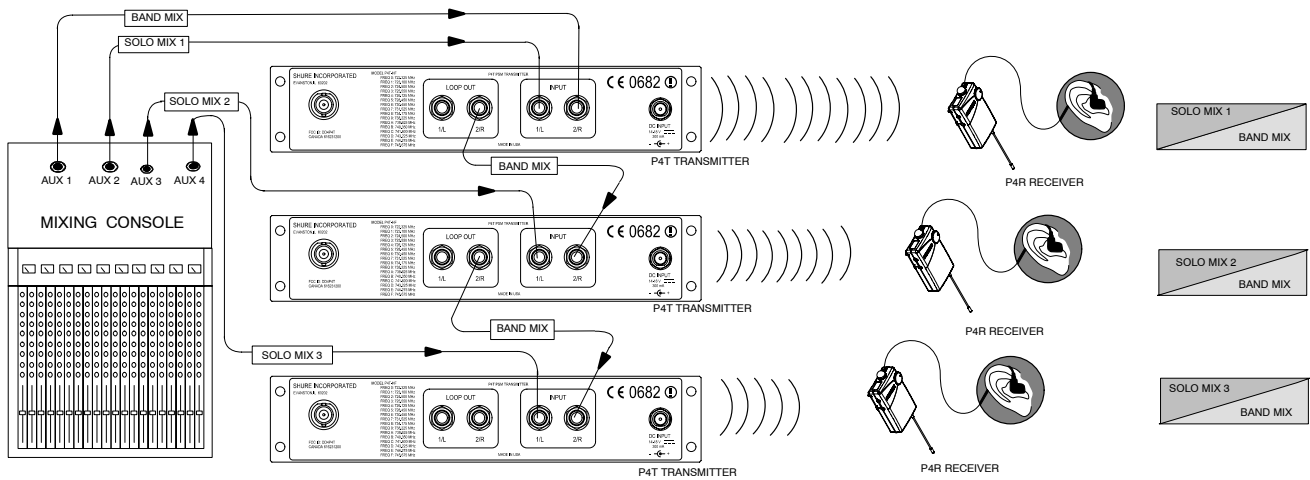

Running Multiple PSM Wireless Systems Under MixMode Control: When using a mixer with multiple auxiliary out jacks, a single monitor mix can be sent to multiple P4T transmitters using the LOOP connectors, and independent monitor mixes or direct outputs can be sent directly to the second channel of each P4T. This allows each P4T user to mix a band mix signal with a solo mix signal using the MixMode feature on the receiver. The thumbwheel on the P4R is used to mix the two signals in relation to one another.

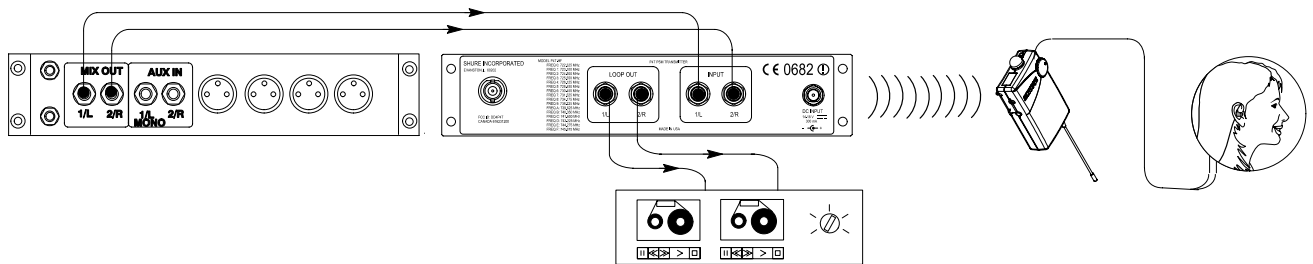

Running a Recording Device Through a P4T Transmitter: If you would like to make a recording of a performance, the LOOP outputs can be connected to the inputs of a tape deck, DAT, or other recording device.

P4R RECEIVER

Controls and Features

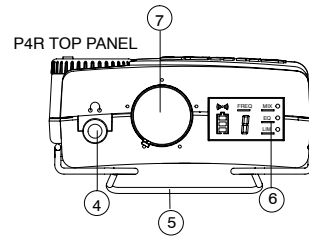
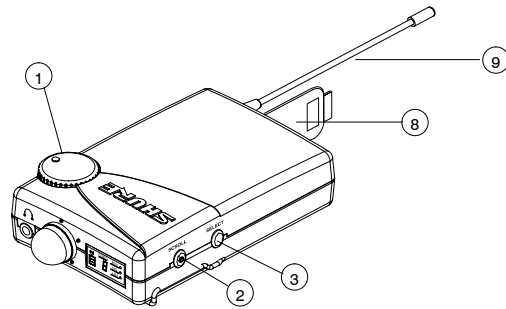

- Balance Knob:** This thumbwheel adjusts the left/right balance when the unit is in stereo and the Mix 1/Mix 2 balance when the unit is in MixMode.
- SCROLL Pushbutton:** Use with the SELECT pushbutton to control the functions in the LCD screen. See *Pushbutton Controls* on page 10.
- SELECT Pushbutton:** Use with the SCROLL pushbutton to control the functions in the LCD screen. See *Pushbutton Controls* on page 10.
- 1/8" Earphone Output Jack:** Connects to earphones.
- Belt Clip:** Securely attaches the receiver to a belt, guitar strap or waist band.
- LCD Screen:** The LCD Screen displays the status of various functions. See *LCD Screen* on page 11.
- ON/OFF/VOLUME Knob:** Turn clockwise past click to turn ON. Continue to turn clockwise to increase volume, counter-clockwise to decrease volume.
- Battery Compartment Door:** See *Battery Installation* on page 10.
- Antenna:** An attached, flexible whip antenna receives radio frequency (RF) from the Transmitter.

Battery Installation

- Open the battery compartment door by pushing down and sliding towards the antenna.
- Insert a fresh 9V alkaline battery with the +/- terminals properly positioned.
- Close the battery compartment door.

Note: If battery compartment door will not close, the battery is not properly inserted.

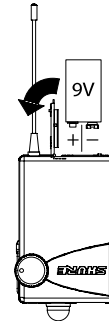

Set-up

- Turn the ON/OFF/VOLUME knob clockwise past click (ON).
- Check the LCD Screen to see if RF is being received. (see *LCD Screen* on page 11).
- Plug earphones into earphone output jack. Insert earphones into ears as instructed in the earphone user's guide.
- Increase the volume slowly until a comfortable listening level is achieved.
- Set the desired functions in the LCD screen as described in *LCD Screen* on page 11.

Pushbutton Controls

Push either the SCROLL or SELECT pushbutton to activate the LCD Screen. Push and hold the SCROLL pushbutton to scroll through the functions. The current function is underscored. Use the SELECT pushbutton to change the status of the underscored function.

Changing the Reception Channels

- Push and hold the SCROLL pushbutton.
- Scroll to **FREQ.**
- Push the SELECT pushbutton to select a channel (0-9 or A-F).
NOTE: Use the same reception channel as the P4T transmitter.
- Push the SCROLL pushbutton to confirm changes.

Changing MixMode, High Frequency Equalization and Limiter Status

- Push and hold the SCROLL pushbutton. Scroll to the desired function (MIX, EQ, or LIM).
- Push the SELECT pushbutton to toggle the function ON or OFF. A function is ON when a dot appears to the right of the function symbol.
- Push the SCROLL pushbutton to confirm changes.

LCD Screen

The LCD Screen on the top panel displays the status of various functions. The status of these functions can be changed using the SCROLL and SELECT pushbuttons (see *Pushbutton Controls* on page 10).

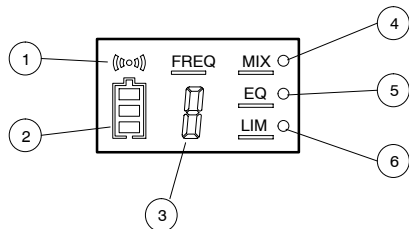

- RF:** Indicates the P4R receiver is receiving a transmission. Always check for RF reception prior to inserting earphones into ears.
- Battery Life Meter:** Indicates the approximate amount of voltage left in the battery. These voltages translate to time as follows:
 - HIGH: 4-8 hours of operation.
 - MEDIUM: 1-4 hours of operation.
 - LOW: less than 1 hours of operation.
- RECEPTION CHANNEL (FREQ):** The P4R receiver features 16 preset, user-selectable channels (0-9 and A-F). The receiver must be set to the same channel as its transmitter.
- MixMode (MIX):** The receiver receives the monitor mix in either MixMode (MIX ON) or stereo (MIX OFF). See *MixMode/Stereo Control* on page 12.

NOTE: If the receiver is receiving only one signal, it will be in mono.
- High Frequency Equalization (EQ):** Adds 6 dB at 10 KHZ for increased treble response.
- Limiter (LIM):** The limiter provides protection against loud signals.

NOTE: If no bars are present within the battery life gauge, change the battery immediately. Battery life depends on many variables, including battery type (brand), earphones used, and receiver volume setting.



WARNING! Turning the Limiter OFF defeats protection against hazardous sound levels!

Locking Out the LCD Screen

Once the receiver's functions are set for use, lock out the LCD screen and pushbuttons to prevent unwanted changes during or between performances. To lock out the front panel:

- Set all functions to desired settings.
- Hold down the SCROLL and SELECT pushbuttons simultaneously for five seconds (A).

NOTE: The reception channel will be replaced by dashes (B) when lock-out is engaged.
- When lock-out is engaged, the SCROLL and SELECT pushbuttons light the LCD screen, but cannot change the status of any of the functions.
- To disengage the lock-out, hold the SCROLL and SELECT pushbuttons for five seconds until the reception channel is displayed again.

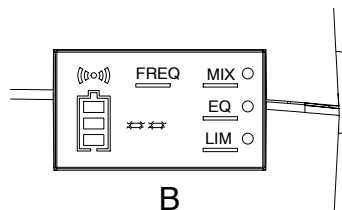
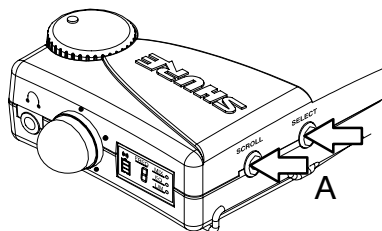

MixMode/Stereo Control

The flexible design of the PSM 400 Wireless Personal Performance Pack makes configuring a monitor mix very simple. In addition, the unique MixMode circuitry enables you to customize your own individual mix in a multiple mix environment.

MixMode Control	Used for mixing and combining an individual mix between two distinct monitor sends.
Stereo Control	Used for conventional stereo monitor mixes.
Mono Control	Used when only one (mono) monitor mix is available.

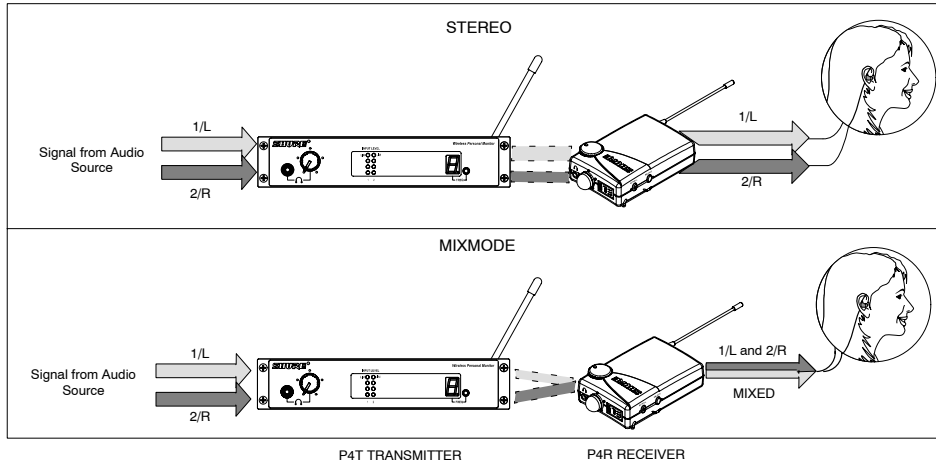

WHAT IS MIXMODE CONTROL?

The P4R receiver receives two signals (1/L and 2/R) from the P4T transmitter. The P4R processes these signals in either MixMode or stereo:

STEREO: In stereo, the signals remain separate so that 1/L is heard through the left earphone and 2/R is heard through the right earphone. The balance knob on the P4R adjusts the balance between the left and right earphones.

MIXMODE: In MixMode, the signals are “mixed” in relation to one another using the balance knob, blended into one signal. The one mixed signal is sent to *both* the left and right earphones.

Using MixMode

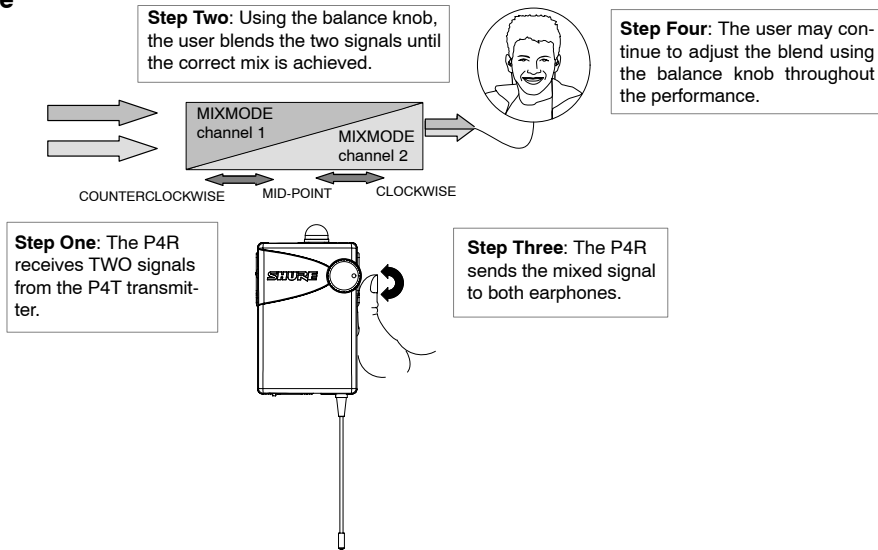

MIXMODE IN APPLICATIONS

MixMode is most useful when two distinct mixes are provided to the P4T transmitter, such as a band mix and a vocal mix. MixMode combines these two signals into one monitor mix and allows you to control this mix *during* the performance using the P4R receiver. For example, if the band overpowers the vocals in the mix, increase the level of the vocals and decrease the level of the band by simply adjusting the balance knob on the receiver.

SYSTEM APPLICATIONS

APPLICATION ONE: One PSM 400 System

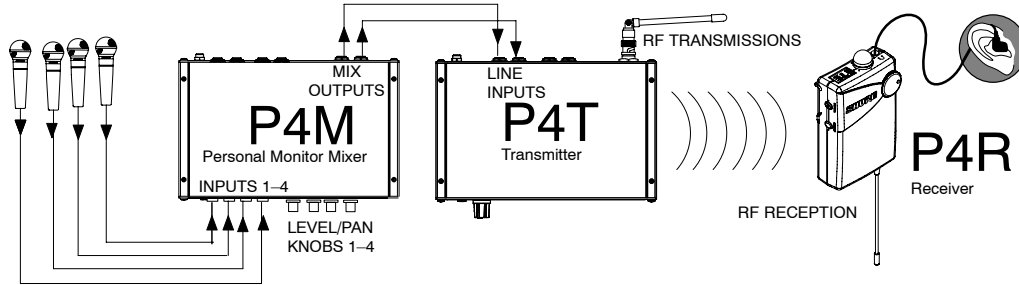

This is the basic configuration of the PSM 400 system and is the recommended configuration for small ensembles in live or rehearsal situations.

1. Connect up to four microphones, instruments or audio devices to the four inputs on the P4M mixer front panel.
2. Connect MIX OUT 1/L and MIX OUT 2/R on the back panel of mixer to INPUT 1/L and INPUT 2/R on the back panel of the P4T transmitter.
3. Mix the four signals using the CONCENTRIC LEVEL/PAN knobs on the front panel of the mixer.
4. Transmit the mix to the receiver.

APPLICATION TWO: Multiple P4M Personal Monitor Mixers to One P4T Transmitter

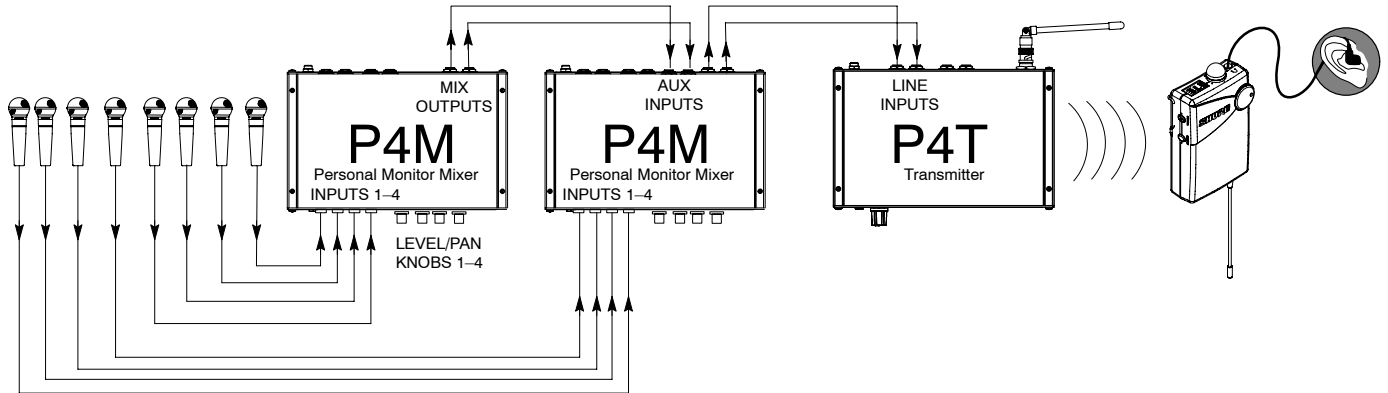

This application, using the P4M's AUX inputs, allows more than four inputs to be mixed. Recommended for large ensembles in live or rehearsal situations.

1. Connect up to four audio sources to the front panel inputs of the P4M mixer.
2. Mix these signals using the CONCENTRIC LEVEL/PAN knobs on the mixer.
3. Connect the MIX OUTPUTS of the first mixer to the AUX INPUTS of a second P4M mixer.
4. Connect up to four more audio sources into the front panel inputs of the second P4M Mixer.
5. Mix these signals using the CONCENTRIC LEVEL/PAN knobs on the second mixer.
6. Connect the MIX OUTPUTS of the second mixer to the LINE INPUTS of the P4T transmitter. The transmitter receives a mix consisting of all eight audio sources, which it transmits to the P4R receiver.

NOTE: If more than eight inputs are required, connect additional P4M mixers between the second mixer and the transmitter using the connection described in step 3 above.

APPLICATION THREE: One P4M Mixer/Two P4T Transmitters

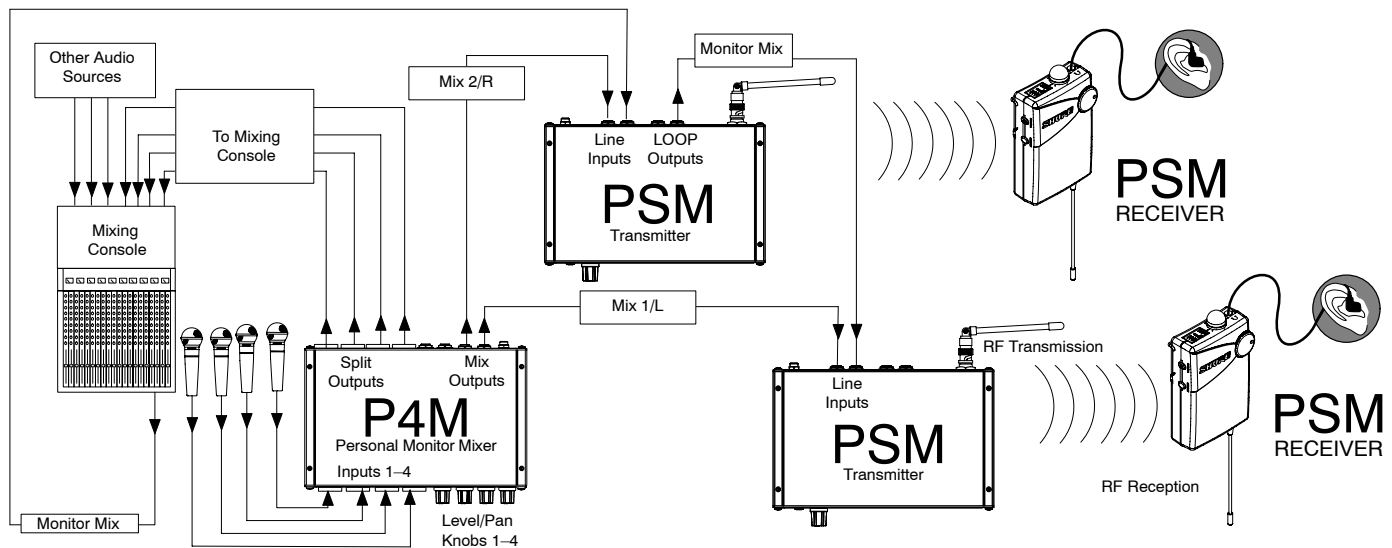

This configuration, using the P4M's SPLIT OUTPUT and a PSM transmitter's LOOP OUTPUT, allows one P4M to provide custom mixes to two PSM transmitters, and is recommended for small ensembles in live performance:

1. Connect up to four microphones or instruments into the P4M inputs. Connect the SPLIT OUTPUTS to a mixing console.
2. Connect a monitor mix from a mixing console to the first P4T transmitter.
3. On the first PSM transmitter, connect the LOOP output containing the monitor mix to an input on the second PSM transmitter.
4. Connect a MIX OUT output to each transmitters' remaining input. Use the front-panel PAN knobs to balance input signals between the two transmitters.
5. Place the PSM receivers in MixMode. Use the balance wheel on the PSM receiver to blend the monitor mix with the custom mix created by the P4M.

APPLICATION FOUR: Multiple PSM 400 Systems

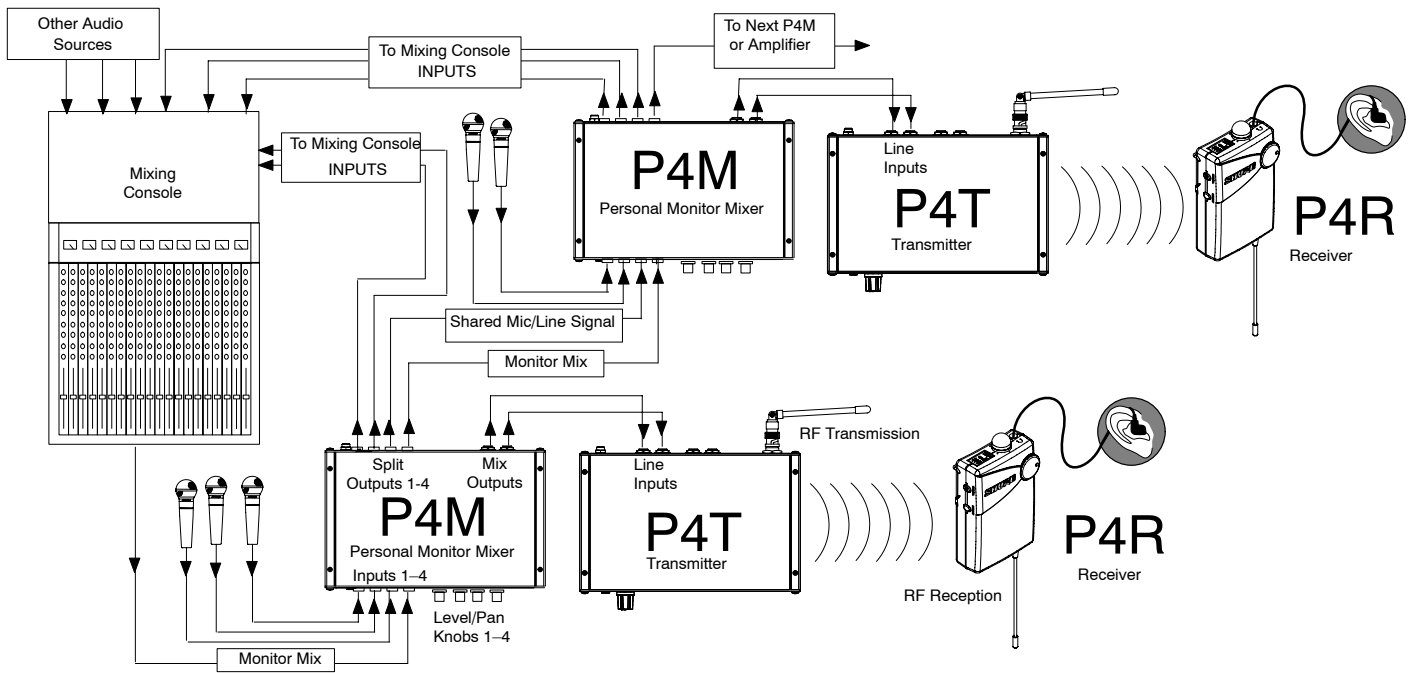

This configuration uses the P4M's SPLIT OUTPUTS to pass audio signal to other P4M Personal Monitor Mixers. Each player can create a custom mix at their mixer. Recommended for live, studio or rehearsal situations.

1. Connect a monitor mix signal (from a mixing console) and up to three audio sources to the four inputs on the mixer's front panel.
2. Connect the SPLIT OUTPUT of the mixer containing the monitor mix to an input on a second mixer.
3. Connect the other SPLIT OUTPUTS from the first mixer to either the second mixer or to the mixing console.
4. On the second mixer, connect the SPLIT OUTPUT containing the monitor mix to a third mixer or to a floor monitor amplifier.
5. Connect MIX OUT 1/L and MIX OUT 2/R on the back panel of each mixer to INPUTS 1/L and 2/R on the back panel of a P4T transmitter.
6. On each mixer, mix the four signals using the CONCENTRIC LEVEL/PAN knobs on the front panel.
7. Transmit the mix from each transmitter to its respective P4R receiver.

TROUBLESHOOTING

PROBLEM	SOLUTION
No sound at the receiver	<ul style="list-style-type: none"> ✓ Check the power cord on the transmitter and make sure it is powered on. ✓ Make sure both the transmitter and the receiver are set to the same frequency. ✓ Make sure the earphones are plugged in to the receiver. ✓ Make sure receiver is on and the battery is good. ✓ Listen to the headphone monitor on the transmitter to check audio feed. ✓ Make sure the antenna is connected to the transmitter. ✓ Check the incoming audio and power connections and the outgoing audio connections at the mixer.
Low receiver range	<ul style="list-style-type: none"> ✓ Try to maintain line-of-sight between transmitter and receiver. ✓ Try another frequency in case interference is limiting the range. ✓ Check for television channel interference.
Receiver sounds fuzzy or distorted	<ul style="list-style-type: none"> ✓ Make sure no other transmitters are operating on your frequency. ✓ Make sure transmitter input level is lighting yellow LEDs for optimum performance. ✓ Listen to the headphone monitor on the transmitter to check audio feed.
Low audio output at the receiver	<ul style="list-style-type: none"> ✓ Make sure transmitter input level is lighting yellow LEDs for optimum performance. ✓ Make sure the P4R receiver's volume knob is up.

SPECIFICATIONS

System Specifications

RF Carrier Frequency Range

722 to 952 MHz (country dependent)

Operating Range

300 ft. (environment dependent)

Audio Frequency Response

50 Hz to 12 kHz (+/-3 dB); earphone dependent

Image Rejection

55 dB typical

Spurious Rejection

60 dB typical

Total Harmonic Distortion (1 KHz)

0.8% typical (Ref. ± 35 KHz deviation)

Modulation

FM ± 35 KHz Deviation (Nominal), MPX Stereo

Channel Separation

35 dB typical

Signal-to-Noise Ratio

80 dB typical (A-weighted)

Operating Temperature

-7° C to +49° C
(+20° F to 120° F)

P4M Mixer Specifications

Measurement Conditions (unless otherwise specified): full gain; 1 KHz, one channel activated; source impedances: Mic 150 Ω , Aux Level 150 Ω ; terminations: Line 600 Ω .

Frequency Response (Ref 1 KHz, controls centered)

20 Hz to 20 KHz ± 2 dB

INPUT Specifications

	Input	
	1-4 (front panel)	Aux In
Gain (Maximum)	43 dB	0 dB
Impedance (at 1kHz)	5800 Ω	18 k Ω (each) 9100 Ω (1/L mono)
Input Clipping Level	+12dBV	+12 dBV
Crosstalk	-100 dB	-90 dB
Common Mode Rejection	> 75 dB	> 70 dB

OUTPUT Specifications

	Output	
	Split 1 - 4	Mix Out
Impedance	N/A	500 Ω
Output Clipping Level	N/A	+5 dBV (10 k Ω balanced load, -30 dBV input ch. 1 - 4.)
Noise (100 Hz to 22 kHz)	-110 dBV	-100 dBV (all controls CCW) -62 dBV (all controls CW)
Distortion (THD) at 1kHz)	.0005%	< .05% (0 dBV output)
Crosstalk	-100 dB	-70 dB

LEDs: Resultant Mix Out Level

Green: -30 dBV

Yellow: -10 dBV

Red: 0dBV

Current

120 mA max.

Power Requirements

Operating voltage 14-18 Vdc

Supplied with one of the following external power supplies:

- Model PS40: 120 Vac, 60 Hz input.
- Model PS40E, Model PS40UK: 230 Vac, 50/60 Hz input.

NOTE: Courtesy DC connector is protected from short by a self-resetting "Polyfuse". Maximum recommended load is 250mA (2 P4Ms or 1 P4T.)

Phantom Power

The P4M does not produce phantom power, but phantom power is allowed to pass through Split Outputs 1-4 to inputs 1-4 respectively.

Audio Polarity

All outputs in polarity with all inputs.

XLR Pin 2 is "hot" with respect to Pin 3; Pin 1 is ground.

1/4" TRS tip is "hot" with respect to ring; sleeve is ground.

Temperature Range

Operating -7° to 49° C (20° to 120° F)

Storage -29° to 74° C (-20° to 165° F)

Overall Dimensions

44 mm H x 218 mm W x 162 mm D

(1.72 x 8.60 x 6.37 inches)

Net Weight

1.20 Kg (2 lbs, 10 oz)

P4T Transmitter Specifications

RF Output Power

50 mW (+17 dBm) typical conducted (country dependent)

Modulation Limiter

Internal peak limiter (>10:1 compression)

Antenna

External whip, 50 Ω BNC connector

Current

250 mA maximum

Dimensions

219.2 mm X 43.6 mm X 136.5 mm (8.6 in. X 1.7 in. X 5.4 in.)

Net Weight

907.2 g (2 lbs., 0 oz.)

CONNECTORS

P4T Audio Inputs (1/L and 2/R)

Connector Type:	1/4-inch jack (female) TRS
Configuration:	electronically balanced
Actual Impedance:	20 k
Nominal Input Level:	-10 dBV/-7.8 dBu
Maximum Input Level:	+15 dBu
Pin Assignments:	Tip = hot ring = cold sleeve = ground
Phantom Power Protection?	Yes Up to 50 VDC

P4T L/R LOOP Outputs (1/L and 2/R)

Connector Type:	1/4-inch jack (female) TRS
Configuration:	electronically balanced
Actual Impedance:	20 k
Nominal Output Level:	-10 dBV/-7.8 dBu
Maximum Output Level:	+15 dBu
Pin Assignments:	Tip = hot ring = cold sleeve = ground
Phantom Power Protection?	Yes Up to 50 VDC

Power Requirements

Operating voltage 14–18 Vdc

Supplied with one of the following external power supplies:

- Model PS40: 120 Vac, 60 Hz input.
- Model PS40E, Model PS40UK: 230 Vac, 50/60 Hz input.

P4R Receiver Specifications

RF Sensitivity

1 µV typical

Image Rejection

55 dB typical

Spurious Rejection

60 dB typical

Squelch Threshold

4.5 µV typical

Antenna

Attached Whip

Power Requirements

9 V alkaline battery

Battery Life

Up to 8 hours, volume dependent

Audio Output Connector

3.5 mm Stereo (Left = tip, Right = ring, Ground = sleeve)

Minimum Load Impedance

16

Net Weight

125 g (.28 lbs.)

Overall Dimensions

82.6 mm X 63.5 mm X 26.2 mm
(3 1/4 in. X 2 1/2 in. X 1 1/32 in.)

Furnished Accessories Transmitter Antenna UA400: 774-952 MHz
 Transmitter Antenna PA715: 524-715 MHz
 Dual Mount Rack Bracket 53B8484
 Straddle Bars 53A8443
 AC Adaptor PS40 (120V), PS40E (230V), PS40UK (230V)
 DC Jumper Cable 95A8420

Optional Accessories
 Antenna Combiner PA770 (120VAC): 720 to 750 MHz
 PA770E (240 VAC): 720 to 750 MHz
 Unidirectional Antenna PA705
 10 ft Coaxial Antenna Cable (BNC connector) PA725

Certifications

P4M: Eligible to bear **CE** mark. Conforms to European Union EMC directive 89/336/EEC. Meets applicable tests and performance criteria in European EMC Standard EN 55103 (1996) parts 1 and 2, for residential (E1) and light industrial (E2) environments.

P4T: Type Accepted under Part 74, FCC ID DD4P4TA. Certified by IC in Canada under RSS-123.

EP4T: Meets the essential requirements of European R&TTE Directive 99/5/EC, eligible to bear CE mark: **CE** O682 **Ø**. Type approved to EN 300 422 Parts 1 and 2. Meets requirements of EMC Standard EN 301 489.

P4R: Approved under the DECLARATION OF CONFORMITY provision of FCC Part 15. Certified in Canada by IC under RSS-123. Meets essential requirements of European Union R&TTE Directive 99/5/EC, eligible to bear **CE** mark. Meets requirements of EMC standards EN 300 422 Parts 1 and 2 and EN 301 489 Parts 1 and 9.

PS40: Conforms to applicable U.S. and Canadian electrical and safety standards

PS40E/PS40UK: Conforms to European low voltage directive 72/23/EEC. Eligible to bear CE marking: **CE**.

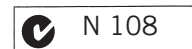

RACK MOUNTING OPTIONS

Rack Mounting the P4T and P4M

Both the P4T and P4M feature a $\frac{1}{2}$ -rack chassis specially designed for sturdiness. The sagging and bending found in most $\frac{1}{2}$ -rack designs is eliminated — the brackets and straddle bars are designed to ensure that the units will be installed securely.

WARNING: Do not torque the screws too tightly, or the chassis may be damaged.

Mounting Units

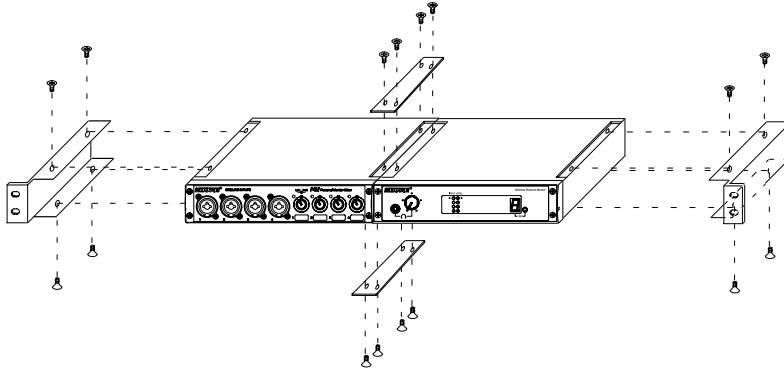

NOTE: Be sure to use both straddle bars when installing dual units.

Mounting in an Equipment Rack

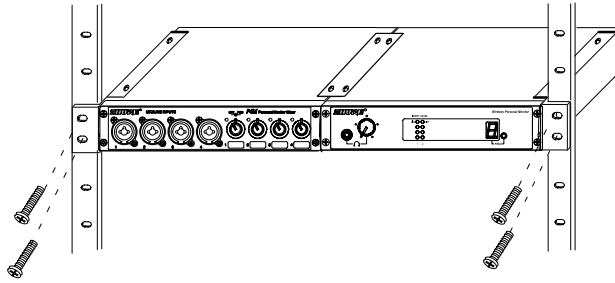

TABLE 1 TABLEAU 1 TABELLE 1 TABLA 1 TABELLA 1

Country Code Code de Pays Länder-Kürzel Código de país Codice del Paese	P4T-HF (722 – 746 MHz)	P4T-P3 (722 – 746 MHz)	P4T-MN (800 – 830 MHz)	P4T-KE (842 – 865 MHz)
A	722 – 746 MHz *	*	800 – 830 MHz *	842 – 865 MHz *
B	722 – 746 MHz *	*	800 – 830 MHz *	842 – 865 MHz *
CH	722 – 746 MHz *	*	800 – 830 MHz *	842 – 865 MHz *
D	722 – 746 MHz *	*	800 – 830 MHz *	842 – 865 MHz *
E	722 – 746 MHz *	*	800 – 830 MHz *	842 – 865 MHz *
F	*	722 – 746 MHz *	*	*
GB	722 – 746 MHz *	*	*	842 – 865 MHz *
GR	722 – 746 MHz *	*	800 – 830 MHz *	842 – 865 MHz *
I	722 – 746 MHz *	*	*	863 – 865 MHz*
IRL	722 – 746 MHz *	*	800 – 830 MHz *	842 – 865 MHz *
L	722 – 746 MHz *	*	800 – 830 MHz *	842 – 865 MHz *
NL	722 – 746 MHz *	*	800 – 830 MHz *	842 – 865 MHz *
P	722 – 746 MHz *	*	800 – 830 MHz *	842 – 865 MHz *
DK	*	*	800 – 820 MHz *	863 – 865 MHz*
FIN	*	*	800,1 – 819,9 MHz *	863 – 865 MHz*
N	*	*	800 – 820 MHz *	863 – 865 MHz*
S	*	*	800 – 814 MHz *	863 – 865 MHz*
All Other Countries Tous les autres pays Alle anderen Länder Demás países Tutti gli altri Paesi	*	*	*	*

*Please contact your national authority for information on available legal frequencies for your area and legal use of the equipment.

*Se mettre en rapport avec les autorités compétentes pour obtenir les informations sur les fréquences autorisées disponibles localement et sur l'utilisation autorisée du matériel.

*Für Informationen bezüglich der für Ihr Gebiet verfügbaren gesetzlich zugelassenen Frequenzen und der gesetzlichen Bestimmungen für den Einsatz der Geräte setzen Sie sich bitte mit der zuständigen örtlichen Behörde in Verbindung.

* Comuníquese con la autoridad nacional para obtener información en cuanto a las frecuencias legales disponibles y usos legales del equipo en su área.

*Rivolgersi alle autorità competenti per ottenere informazioni relative alle frequenze autorizzate nella propria regione e alle norme che regolano l'uso di questo apparecchio.

Declaration of Conformity

We, of

Shure Incorporated
5800 W. Touhy Avenue
Niles IL 60714-4608 U.S.A.
847-600-2000

Declare under our sole responsibility that the following product,

Model: P4R Description: Receiver

Has been tested and found to comply with the limits for an unintentional radiator device, and approved under the Declaration of Conformity provision of the Part 15 of the FCC rules.

Operation is subject to the following two conditions:

1. This device may not cause harmful interference
2. This device must accept any interference received, including interference that may cause undesired operation.

Shure Incorporated., Manufacturer.

Signed:



November 12th, 2003

Name, Title: Craig Kozokar, EMCProject Engineer,
Corporate Quality, Shure Incorporated

EU DECLARATION OF CONFORMITY

We,
of

Shure Incorporated
5800 W. Touhy Avenue
Niles, IL 60714-4608, U.S.A.

Declare under our sole responsibility that the following products

Model: P4T	Description: Transmitter
Model: P4R	Description: Receiver
Model: P4M	Description: 4-Channel Mixer
Model: PS40E, PS40UK	Description: AC/DC Power Adapter

Conform to the essential requirements and other relevant provisions of the R&TTE Directive (1995/5/EC).

The products comply with the following product family, harmonized or national standards:

P4T:	ETSI EN 300 422-1	ETSI EN 300 422-2
	ETSI EN 301 489 Part 1 and 9	
P4R:	ETSI EN 300 422-1	ETSI EN 300 422-2
	ETSI EN 301 489 Part 1 and 9	
P4M:	EN55103-1	EN55103-2
PS40E/PS40UK:	EN60950, EN6100-3-2, EN6100-3-3	

Manufacturer: Shure Incorporated

Signed:



Date: October 27, 2003

Name, Title: Craig Kozokar
EMC Project Engineer, Corporate Quality,
Shure Incorporated

European Contact: Shure Europe GmbH
Wannäcker Str. 28, 74078 Heilbronn, Germany
Phone: 49-7131-7214-0, Fax: 49-7131-7214-14

Note: This equipment has been tested and found to comply with the limits for a Class B digital device, pursuant to part 15 of FCC Rules. These limits are designed to provide reasonable protection against harmful interference in a residential installation. This equipment generates, uses and can radiate radio frequency energy and, if not installed and used in accordance with the instructions, may cause harmful interference to radio communications. However, there is no guarantee that interference will not occur in a particular installation. If this equipment does cause harmful interference to radio or television reception, which can be determined by turning the equipment off and on, the user is encouraged to try to correct the interference by one or more of the following measures:

- Reorient or relocate the receiving antenna.
- Increase the separation between the equipment and the receiver.
- Connect the equipment into an outlet on a circuit different from that to which the receiver is connected.
- Consult the dealer or an experienced radio/TV technician for help.

SHURE®

SHURE Incorporated <http://www.shure.com>
United States, Canada, Latin America, Caribbean:
5800 W. Touhy Avenue, Niles, IL 60714-4608, U.S.A.
Phone: 847-600-2000 U.S. Fax: 847-600-1212 Intl Fax: 847-600-6446
Europe, Middle East, Africa:
Shure Europe GmbH, Phone: 49-7131-72140 Fax: 49-7131-721414
Asia, Pacific:
Shure Asia Limited, Phone: 852-2893-4290 Fax: 852-2893-4055