



# The Twin Pro Wireless Microphone System User Guide

---



# The Twin Pro™ Wireless Microphone System User Guide

**TABLE OF CONTENTS — ENGLISH**

<b>Introduction</b> .....	<i>English – 1</i>
<b>Description</b> .....	<i>English – 1</i>
<b>Using the T88 Wireless Receiver</b> .....	<i>English – 3</i>
<b>Using the T2 Hand-Held Microphone Transmitter</b> .....	<i>English – 3</i>
<b>Using the T1 Body-Pack Transmitter</b> .....	<i>English – 4</i>
<b>Tips and Troubleshooting</b> .....	<i>English – 5</i>
<b>Specifications and Information</b> .....	<i>English – 6</i>

## INTRODUCTION

The Twin Pro™ Wireless System is the finest in its class. This system will give you excellent performance for years to come.

### System Contents

The Twin Pro Wireless System contains the following components:

- One T88 dual channel wireless receiver
- Two transmitters available in one of three different combinations (see *System Combinations* below)
- One PS20 (120 Vac) or PS20E (230 Vac) power adapter
- One plastic screwdriver for squelch adjustment

### System Combinations

The Twin Pro system includes one of the following three transmitter combinations:

- Two handheld microphone transmitters (includes two swivel adapters and two anti-roll devices)  
or
- Two body-pack transmitters with lavalier microphones  
or
- One handheld microphone and one body-pack transmitter (includes one swivel adapter and one anti-roll device)

## DESCRIPTION

### T88 Wireless Receiver (Figure 1)

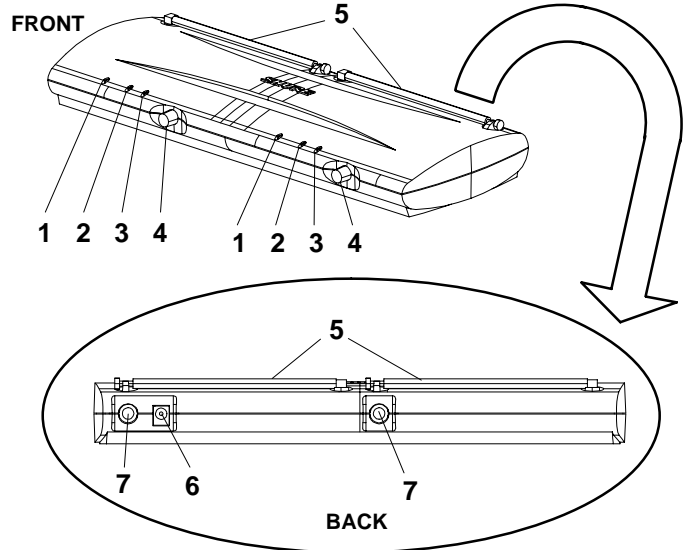

FIGURE 1

- 1 Power Indicators.**
- 2 RF Signal Indicators.** Yellow indicates when RF (radio frequency) signals are received from the transmitter.
- 3 Audio Peak Indicators.** These lights flicker occasionally in normal operation. They are ON steadily when the audio input is overloaded.
- 4 Volume Controllers.** Controls the audio output level.
- 5 Telescoping Antennas.** Receive signals from the transmitters. Make sure the antennas are fully extended vertically.
- 6 Power Input Connector.** Connects to a PS20 (120 Vac) or PS20E (230 Vac) power adapter.
- 7 Independent Audio Output Connectors.** There is a separate, unbalanced 1/4 inch phone jack for each channel.

## T2 Handheld Microphone Transmitter (Figure 2)

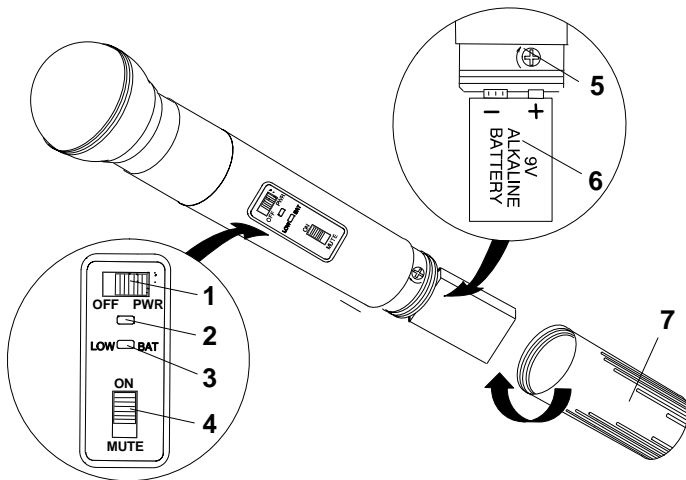

FIGURE 2

- 1 **POWER ON/OFF Switch.**
- 2 **POWER Indicator.**
- 3 **LOW BATTERY Indicator.** Red light glows when you have one hour or less of useful operating time; when this light glows, change the battery.
- 4 **MIC ON/MUTE Switch.** Lets you turn the microphone audio on and off (muting the microphone).
- 5 **Audio Gain Control.** Provides audio level adjustment to accommodate different sound sources.
- 6 **9V Alkaline Battery (shown installed).** Provides power to the microphone-transmitter. Typical battery life is 18 hours.
- 7 **Battery Cover.** Unscrews for access to the 9V alkaline battery and gain control.

## T1 Body-Pack Transmitter (Figure 3)

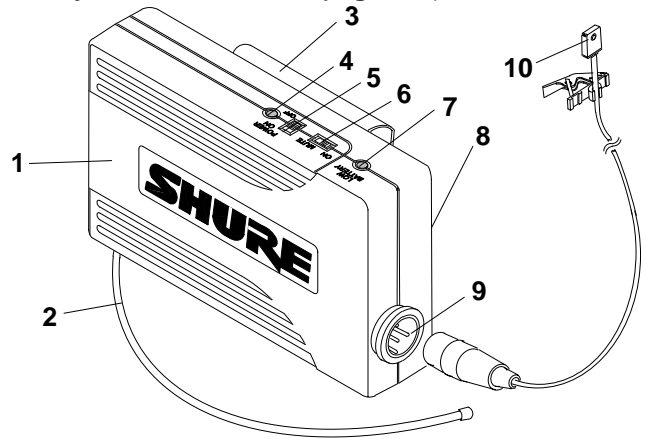
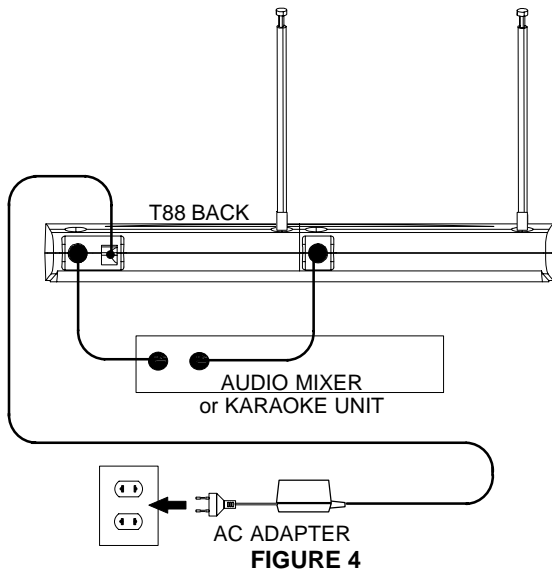

FIGURE 3

- 1 **Battery Compartment.**
- 2 **Antenna.** For best operation, the antenna **must** hang vertically, and should not be coiled or bundled.
- 3 **Belt Clip.**
- 4 **POWER Indicator.**
- 5 **POWER ON/OFF Switch.**
- 6 **Audio ON/MUTE Switch.** Mutes the transmitter to prevent unwanted sounds from being picked up by the receiver *without* turning the transmitter off.
- 7 **LOW BATTERY Indicator.** When this red light is glowing, you have one hour or less of useful operating time; change the battery.
- 8 **Audio Gain Control.** Provides audio level adjustment to accommodate different sound sources (e.g., speaking or playing an instrument). The factory setting is at mid-point. A small screwdriver is supplied to make adjustments.
- 9 **Microphone Input Connector.** 4-Pin miniature connector provides connection to a variety of lavalier and headset microphone cables, and the Shure WA302 instrument adapter cable.
- 10 **Lavalier Microphone.** Condenser lavalier microphone supplied with a mount that clips onto a tie, lapel, or acoustic instrument.

## USING THE T88 WIRELESS RECEIVER

### Connecting the T88 Wireless Receiver



1. Connect the receiver outputs for channels 1 and 2 to the mixer or karaoke unit using unbalanced, single-conductor, shielded cables with 1/4-inch phone plugs.
2. Connect the ac adapter to the POWER jack on the rear panel of the receiver.
3. Plug the ac adapter into an appropriate power outlet.

### Squelch Adjustment

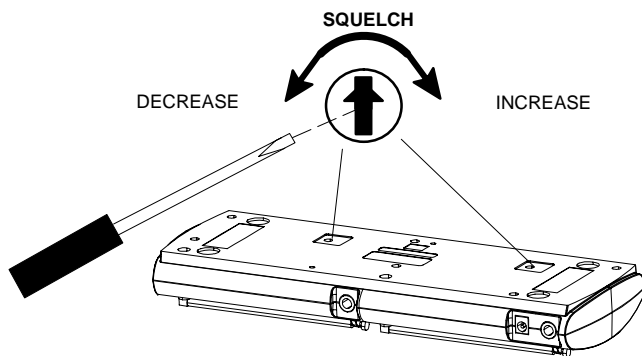

FIGURE 5

**The receiver squelch control is factory preset at the 12 o'clock position for optimum performance. No further adjustment is normally required.** However, it is possible to adjust the squelch control to emphasize either *signal quality* or *system range*.

- To raise the squelch threshold, rotate the control clockwise. This causes the receiver to demand a higher quality signal (less noise before muting), but it *reduces* the operating range.
- To lower the squelch threshold, rotate the control counterclockwise. This allows a lower quality signal through (more noise before muting), but it *extends* the operating range.

## USING THE T2 HAND HELD MICROPHONE TRANSMITTERS

### Operating the T2 Hand Held Microphone Transmitters

1. Press the POWER switch on the T88 receiver ON.
  2. Slide the transmitter POWER ON/OFF switch to the ON position. Check the battery level. If the LOW BATTERY indicator is lit, see *Transmitter Battery Installation*.
  3. Check the RF indicator on the T88 receiver to see if the radio signal is being received.
  4. Slide the MIC ON/MUTE switch to the ON position and begin speaking or singing.
- NOTE:** If the red PEAK light on the receiver does not flicker during the loudest sounds, the transmitter gain may need to be increased. See the *Transmitter Audio Gain Adjustment* section.
5. During the performance or presentation, slide the MIC ON/MUTE switch to the MUTE position when the microphone is not being used.
  6. When the performance or presentation is over, slide the transmitter POWER ON/OFF switch to the OFF position to conserve battery power.

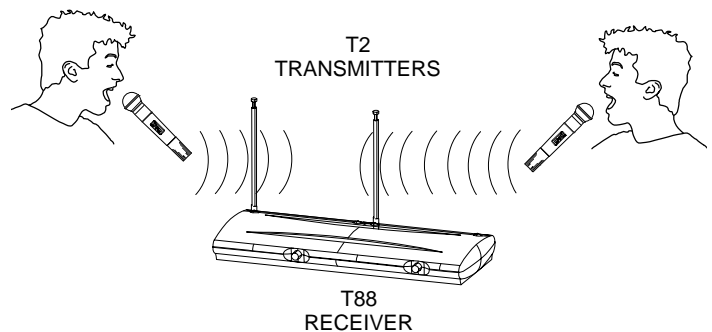

FIGURE 6

### Transmitter Battery Installation

1. Slide the transmitter POWER ON/OFF switch to the OFF position.
2. Unscrew the transmitter battery cover to expose the battery terminals, as shown in Figure 7.

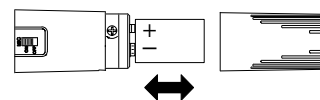

FIGURE 7

3. Insert a fresh 9V alkaline battery into the battery compartment as shown in Figure 7 (Duracell MN1604 recommended and included with the system). A fresh 9V alkaline battery should typically provide 18 hours of performance time. A fully charged 8.4V NiCad battery should provide 2 hours of performance time. When the LOW BATTERY light on the transmitter turns on, you have 1 hour or less of useful battery life remaining; change the battery at your first opportunity.

**IMPORTANT:** Carbon-zinc and zinc-chloride batteries will not provide adequate power and are not recommended.

4. Replace the battery cover.

## Installing the Anti-Roll Device

The rubber anti-roll device prevents hand-held microphones from rolling off onto the ground when they are set down on a flat surface, such as a table or speaker cabinet. The anti-roll device proves an important safeguard in stage situations where the T2 may be used by inexperienced microphone handlers.

To install the anti-roll device, simply slip it over the microphone handle and slide it up so that it is positioned just below the label under the microphone grille, as shown in Figure 8.

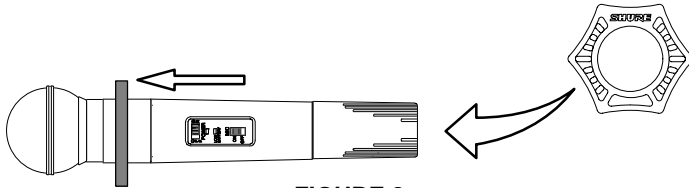

FIGURE 8

## Gain Adjustment

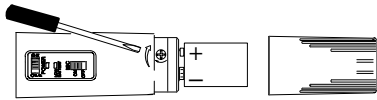

FIGURE 9

The transmitter audio gain control has been factory preset to provide satisfactory output. However, if the PEAK light on the T88 receiver is constantly on or never on, the transmit audio level may require adjustment. Use the gain controls as follows to adjust the equipment for the best sound quality.

To adjust the audio gain, locate the transmitter audio gain control and use the supplied screwdriver to adjust the control.

- If the PEAK light is always on, decrease the audio gain by turning the gain control counter-clockwise (while the vocalist is singing or the musical instrument is being played) until the PEAK light on the receiver flickers only occasionally.
- If the PEAK light is never on, increase the audio gain by turning the gain control clockwise (while the vocalist is singing or the musical instrument is being played) until the PEAK light on the receiver flickers only occasionally.

## USING THE T1 BODY-PACK TRANSMITTERS

### Operating T1 Body-Pack Transmitters

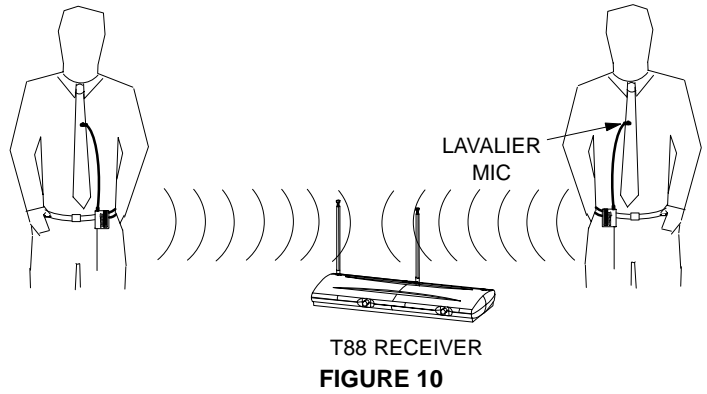

T88 RECEIVER  
FIGURE 10

**NOTE:** The T1 body-pack system is designed for use with other equipment, such as lavalier microphones, guitars, headset microphones, etc. See your Shure dealer for details on ordering the proper equipment for your needs.

1. Clip the T1 body pack transmitter to your belt or guitar strap.
2. Connect the lavalier microphone, headset or instrument adapter cable to the body-pack transmitter.
3. Turn the transmitter POWER switch ON. Check Power/Battery fuel gauge.
4. Check the RF Signal Indicator on the T88 receiver to see if the RF signal is being received.
5. Slide the transmitter ON/MUTE switch to the ON position and begin speaking or playing your instrument.

**NOTE:** If the red PEAK light on the receiver does not flicker during the loudest sounds, the transmitter gain may need to be increased. See the *Transmitter Audio Gain Adjustment* section.

6. During the performance or presentation, slide the ON/MUTE switch to the MUTE position when the system is not being used.
7. When the performance or presentation is over, slide the transmitter POWER ON/OFF switch to the OFF position to conserve battery power.

## Transmitter Battery Installation

1. Slide the transmitter POWER ON/OFF switch to the OFF position.
2. Press down on the OPEN side of the battery compartment cover, slide it back and flip it open, as shown in Figure 11.

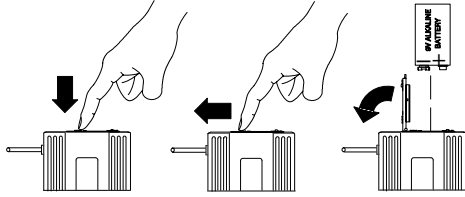

FIGURE 11

3. Insert a fresh 9V alkaline battery into the battery compartment as shown in Figure 11 (Duracell MN1604 recommended and included with the system). A fresh 9V alkaline battery should typically provide 18 hours of performance time. A fully charged 8.4V NiCad battery should provide 2 hours of performance time. When the red LOW BATTERY light on the transmitter glows, you have 1 hour or less of useful battery life remaining; change the battery at your first opportunity.

**IMPORTANT:** Carbon-zinc and zinc-chloride batteries will not provide adequate power and are not recommended.

4. Replace the battery cover.

## Transmitter audio gain adjustment

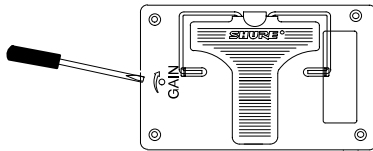

FIGURE 12

The transmitter audio gain control has been factory preset to provide satisfactory output. However, if the PEAK light on the T88 receiver is constantly on or never on, the transmit audio level may require adjustment. Use the gain controls as follows to adjust the equipment for the best sound quality.

To adjust the audio gain, locate the transmitter audio gain control and use the supplied screwdriver to adjust the control.

- If the PEAK light is always on, decrease the audio gain by turning the gain control counter-clockwise (while the vocalist is singing or the musical instrument is being played) until the PEAK light on the receiver flickers only occasionally.
- If the PEAK light is never on, increase the audio gain by turning the gain control clockwise (while the vocalist is singing or the musical instrument is being played) until the PEAK light on the receiver flickers only occasionally.

## TIPS AND TROUBLESHOOTING

### Tips for getting the best performance

- Maintain a line-of-sight between the transmitter and receiver antennas.
- Keep the receiver and antennas away from large metal objects.
- Avoid placing the receiver near computers or other RF generating equipment.
- Point the receiver antennas straight up.
- Avoid placing the receiver in the bottom of an equipment rack unless the antennas are remotely located.

### Troubleshooting

Some common problems and their solutions are identified in the table below. If you are unable to solve a problem, contact your dealer.

Problem	Solution
No sound; RF light(s) not glowing.	<ul style="list-style-type: none"> <li>• Make sure the transmitter POWER switch is ON and the receiver is plugged into a power source.</li> <li>• Check battery.</li> <li>• Check receiver squelch setting.</li> <li>• Check receiver antenna connection(s).</li> <li>• Make sure antennas are in line of sight of transmitter.</li> </ul>
No sound; RF and Audio Level meter lights glowing.	<ul style="list-style-type: none"> <li>• Turn up receiver audio VOLUME control.</li> <li>• Check for proper connection between receiver and karaoke unit.</li> <li>• Talk into microphone and observe receiver audio level lights. If they glow, the problem is elsewhere in the sound system.</li> </ul>
Received signal is noisy or contains extraneous sounds with transmitter on.	<ul style="list-style-type: none"> <li>• Check battery.</li> <li>• Remove local sources of RF interference.</li> <li>• If using a guitar or other instrument, check connections.</li> <li>• Two transmitters may be operating on the same frequency. Locate and turn one off.</li> <li>• Signal may be too weak. Reposition antennas. If possible, move them closer to transmitter.</li> </ul>
Noise from receiver with transmitter off.	<ul style="list-style-type: none"> <li>• Adjust receiver squelch control.</li> <li>• Remove local sources of RF interference.</li> <li>• Reposition receiver or antennas.</li> </ul>
Momentary loss of sound as transmitter is moved around performing area.	<ul style="list-style-type: none"> <li>• Reposition receiver and perform another "walkthrough" test and observe the RF indicators. If audio dropouts persist, mark these "dead spots" in performing area and avoid them during performance.</li> </ul>

## SPECIFICATIONS AND INFORMATION

### Specifications

#### RF Carrier Frequency Range

169.445 to 216.000 MHz

#### Working Range

100 m (approximately 300 ft) under typical conditions.

#### Audio Frequency Response

50 to 15,000 Hz,  $\pm 2$  dB.

#### Audio Output Level ( $\pm 15$ kHz deviation, 1 kHz tone)

$1/4$ -inch connector (into 3 k $\Omega$  load): -8.8 dBV (Hi Z)

#### Audio Connectors

Model:	T88	T1
Connector Type:	$1/4$ -inch phone plug (female)	4-Pin miniature connector (TA4F)
Configuration:	active unbalanced	active unbalanced
Actual Impedance:	3 k $\Omega$	18 k $\Omega$ with lavalier
Maximum Input Level:	—	12.2 dBu
Maximum Output Level:	0 dBu	—
Pin Assignments:	Tip = hot sleeve = ground	pin 1 = ground pin 2 = +5 V pin 3 = audio pin 4 = through 20 k $\Omega$ resistor to ground
Phantom Power Protection:	yes	—
Voltage:	—	+5 V

#### RF Power Output

T1, T2/14A: 50 mW maximum (complies with FCC and IC regulations)

#### RF Sensitivity

-101 dBm, typical

#### System Distortion (ref. $\pm 15$ kHz deviation, 1 kHz modulation)

0.7%

#### Power Requirements

T1, T2/14A: 9V alkaline battery (Duracell MN1604 recommended). 8.4V Nicad (rechargeable) are optional but not recommended.

T88: 12 Vdc (PS20, 120Vac; PS20E, 230 Vac Power Supply)

#### Current Drain

T1: 31 mA average (40 mA max), T2/14A: 30 mA average (35 mA max)

T88: 160 mA average (195 mA max)

#### Operating Temperature Range

-20° to 50° C (-4° to 122° F). **NOTE:** Battery characteristics may limit this range.

#### Overall Dimensions

T1: 82.6 mm H x 63.5 mm W x 26.2 mm D

T2/14A: 241 mm L x 50.8 mm Dia.

T88: 44 mm H x 349 mm W x 194mm D

#### Net Weight

T1: 79.5 g without battery

T2/14A: 294.8 g without battery

T88: 435 g

#### Certification

T1, T2: Type-accepted under FCC Parts 90 and 74; IC certified under TRC-78

T88: Approved under the Notification provision of FCC Part 15

PS20 Power Supply: Conforms to safety standard UL1310. Canada/CSA 22 2 No. 223.

PS20E Power Supply: Conforms to safety standard EN 60065

PS20UK Power Supply: Conforms to safety standard EN 60065.

#### Furnished Accessories

Plastic Screwdriver ..... 65A1659  
Swivel Adapter (hand-held only) ..... WA370A  
Anti-Roll Device (hand-held only) ..... 66A8043

#### Optional Accessories

Microphone Adapter Cable (T1) ..... WA310  
4-Pin Female Mini Connector TA4F (T1) ..... WA330  
In-Line Audio Switch (T1) ..... WA360  
1.8 Meter (6 ft.) Receiver-Mixer Cable ..... WA410  
6.1 Meter (20 ft.) Antenna Extension Cable ..... WA421

#### Replacement Parts

14A Cartridge with Grille ..... R200  
AC Adapter ..... PS20 (120 Vac)/PS20E (230 Vac)  
Grille (T2/14A) ..... RK143G  
Belt Clip (T1) ..... 53A8247A  
 $1/4$ -Wave Antenna ..... 90A8380

#### T1 Pin Connections

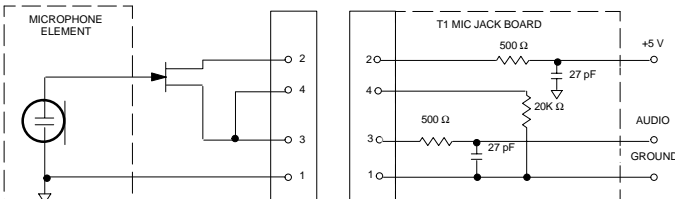

**NOTE:** LAVALIER MIC TIES PINS 3 AND 4 TOGETHER; GUITAR CABLE DOES NOT.

#### T88 Output Wiring ( $1/4$ -in. male plug to output connector)

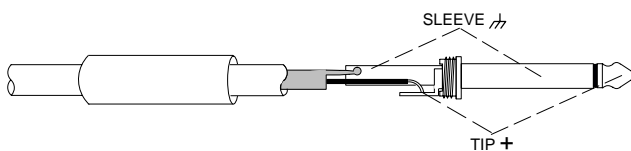

#### Gain Adjustment Range

T1: 40 dB

T2/14A: 25 dB



## **Licensing Information**

Changes or modifications not expressly approved by Shure Inc. could void your authority to operate the equipment. Licensing of Shure wireless microphone equipment is the user's responsibility, and licensability depends on the user's classification and application, and on the selected frequency. Shure strongly urges the user to contact the appropriate telecommunications authority concerning proper licensing, and before choosing and ordering frequencies other than standard frequencies.

## **Warranty Information**

Shure Incorporated ("Shure") hereby warrants that these products will be free from defects in material and workmanship for a period of one year from the date of purchase. At its option, Shure will repair or replace the defective product and promptly return it to you, or refund the purchase price. Retain proof of purchase to validate the purchase date and return it with any warranty claim. If you believe this product is defective within the warranty period, carefully repack the unit, insure it, and return it postpaid to:

**Shure Incorporated  
Attention: Service Department  
222 Hartrey Avenue  
Evanston, IL 60202-3696 U.S.A.  
Telephone: (847) 866-5730**

For service outside the United States, return the product to any authorized Shure Distribution Center.

All claims of defects or shortage should be directed to the above address. Please furnish model number, operating frequency, and date, place and proof of purchase (such as a copy of your sales receipt) to establish warranty. Your letter should include all pertinent details including applicable model or part numbers and a brief description of the problem. Do not mail any units or parts to Shure unless requested to do so by Shure's Service Department. Any returned items must have prior authorization. Unauthorized returns are delayed in handling; these delays can be avoided by contacting Shure in advance and furnishing the necessary information.

Shure reserves the right to make design changes and product improvements on any previously manufactured products. Shure also reserves the right to ship new and/or improved products which are similar to the form, fit and function of the originally ordered products.



**SHURE Incorporated** Web Address: <http://www.shure.com>  
222 Hartrey Avenue, Evanston, IL 60202-3696, U.S.A.  
Phone: 847-866-2200 Fax: 847-866-2279  
In Europe, Phone: 49-7131-72140 Fax: 49-7131-721414  
In Asia, Phone: 852-2893-4290 Fax: 852-2893-4055  
Elsewhere, Phone: 847-866-2200 Fax: 847-866-2585