

The **Reflexion Filter**



User Manual

For further information on this, or any other sE Electronics products, and to register your product for a free extension of your 2 year warranty, please visit our website.



Sound Engineering

www.seelectronics.com

Thank You!

Dear sE customer,

Thank you for purchasing the Reflexion Filter 'portable vocal booth'.

The main idea behind this product is to facilitate 'dry' vocal recordings, in other words to achieve a vocal recording which has greatly reduced room ambience. Of course, the same Reflexion Filter can be used to achieve similar results whilst recording various live instruments, for isolating vocals in rehearsal studios and probably a host of things we haven't thought of yet too! We'd be very interested to hear about novel applications from you, so please do contact us with your ideas, we are always glad to listen as it helps us improve and develop the product, and the information we can supply to other sE users.

Your Reflexion Filter carries a 2 year manufacturing warranty, with free replacement of parts in case of mechanical failure due to faulty components. This warranty does not cover failures deemed to be as a result of misuse or abuse of the Reflexion Filter. If properly used and looked after, it should last a lifetime of recording use.

You can extend your free 2 year warranty to three years by registering your product at www.seelectronics.com, so please visit the site and leave your details. You can also subscribe to the sE newsletter which we email out once every few months (don't worry, we won't pass your details on to anyone else, and we won't bombard you with SPAM!)

One last thing... please read this assembly manual to get the best results from your Reflexion Filter... mic positioning, and the stand clamp assembly are critical to getting best results.

Thank you again, and we look forward to hearing from you,



Siwei Zou
CEO
sE Electronics International

A Few Notes about the Reflexion Filter

What is the Reflexion Filter?

The Reflexion Filter is basically a portable device for recording live sound sources with reduced room ambience. It is an advanced composite wall which is positioned behind any microphone by means of a variable position stand clamp assembly which ships with the product. The main function is to help obtain a 'dry' vocal or instrument recording. This is especially useful in studios without proper acoustic treatment, but can also be used to help record takes in control rooms, where the performer also has to operate the recording device, or in rehearsal studios to reduce ambient noise.

The Technical Bit:

The Reflexion Filter has 6 main layers. Firstly, a strong layer of punched Aluminium which allows sound waves to pass through it, diffused, to a layer of absorptive wool. The sound waves then hit a layer of Aluminium foil which helps dissipate energy and break up the lower frequency wave-forms, and from here they hit an air space kept open by rods passing through the various layers. The air gap acts as an acoustic barrier. The sound waves then pass to a further layer of wool and then through an outer, punched, Aluminium wall which further serve to absorb then diffuse the remaining acoustic energy.

The main absorber has 4 formed pieces of state-of-the-art specialist acoustic absorptive material attached to its face via the extended separation rods, which further serve to absorb and then diffuse the sound waves as they pass to the main filter.

The stand assembly comprises a mic stand clamp fitting, which attaches by means of a vertical joint to the horizontal bar assembly onto which both the Reflexion Filter, and any standard fitting shock mount can be fixed. The microphone (in its shock mount) can then be moved both vertically and horizontally along the bar, and the Reflexion Filter itself can be moved vertically to obtain the optimum working position.

How does it work?

The various layers both absorb and diffuse the sound waves hitting them, so progressively less of the original source acoustic energy passes through each layer. This reduces the amount of energy hitting un-treated walls and other surfaces so there is less of the original source reflected back as unwanted room ambience to the mic. The Reflexion Filter also helps prevent any reflected sound reaching the back and sides of the mic. Its shape and size have been carefully tested to maximize absorption while keeping 'coloration' down to only around 1dB, and leaving the microphone's polar pattern unaffected.

In summary:

All in all, it's a very clever and desirable piece of kit. It allows you to record vocals, guitars etc with a 'drier' sound without having to have an acoustically treated room. It's portable. It uses state of the art materials. It works... and it's a fraction of the price of acoustically treating your studio environment!

Assembling your Reflexion Filter

- 1 Remove the Reflexion Filter and stand assembly unit from the packaging. Please keep the packaging safe to store the Reflexion Filter when not in use, or for transportation. It is robust, but parts may get damaged or lost in transit if not packaged properly.

You should have the following parts
– Reflexion Filter (curved wall), stand assembly, support rod and spanner to fit support rod.

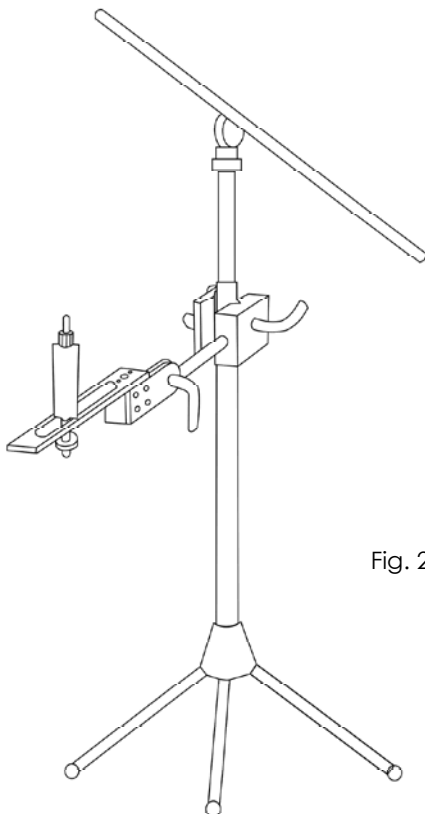

Fig. 2

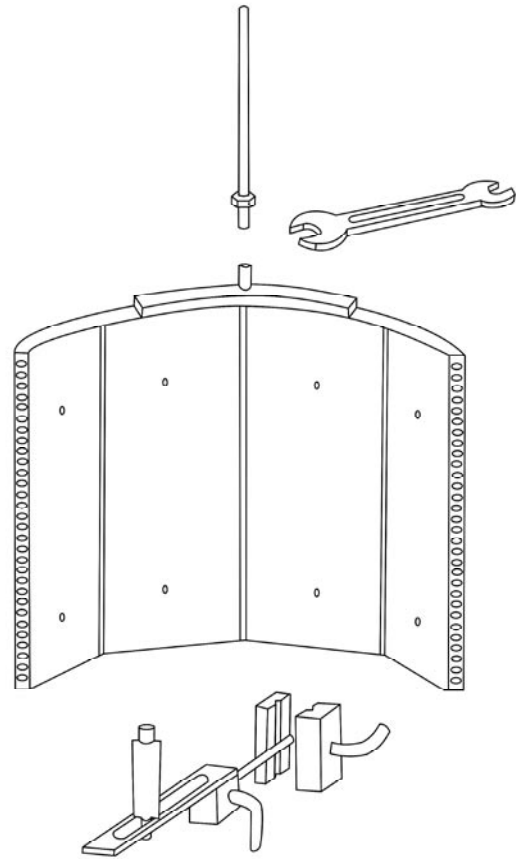

Fig. 1

- 2 Fix the stand clamp assembly in place on the neck of your microphone stand a few inches below the point where the shock mount is usually fixed, or on the main vertical support strut of the stand.

You'll see the assembly has a metal block with two large screws and a handle on it (one of the screws has a spring to help lock the assembly firmly onto the mic stand).

Mic stand booms vary in diameter so you'll need to experiment to get the clamp just right, but basically you need to set the screw with the spring so the two parts of the clamp sit parallel to each other, and then tighten the clamp using the larger screw.

- 3** Fix the support rod to the Reflexion Filter by screwing it into the socket on the bottom edge. Tighten the nut using the spanner supplied in the box.

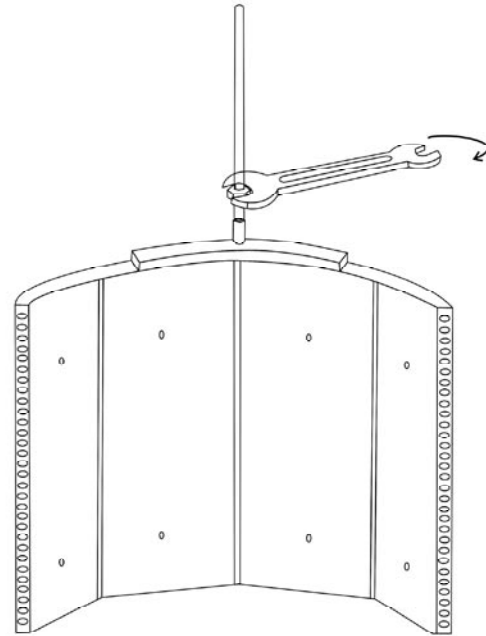

Fig. 3

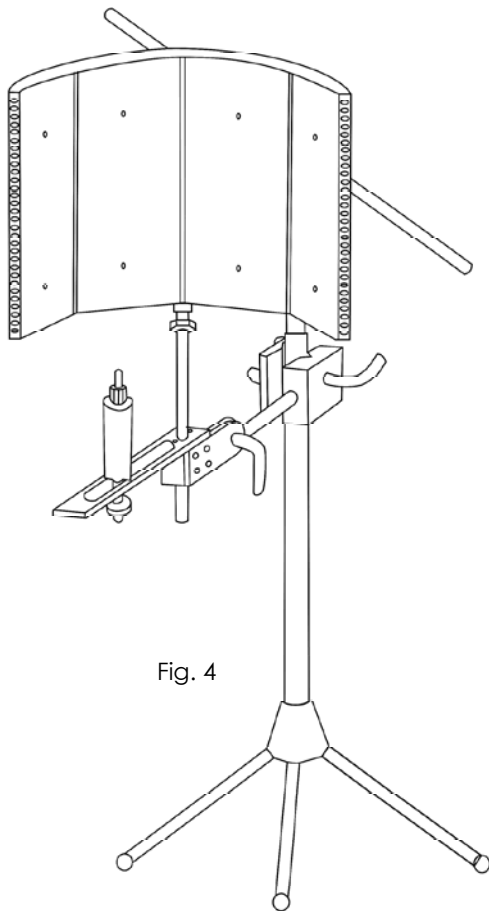

Fig. 4

- 4** Fix the support rod, with the attached Reflexion Filter, by pushing the support rod down into the socket on the stand clamp and tighten it in place with the metal handle on the block.
- 5** You can now play with the positioning of the mic (both vertically and horizontally), and the height of the Reflexion Filter to get the optimum position for recording.

Perfect Position.....!

The 'perfect position' to achieve a 'dry' recording is to place of the microphone so that the mic capsule sits centrally (both vertically and horizontally) in relation to the face of the Reflexion Filter (the face is the convex side with coloured panels). It is also important to have the mic capsule of the correct distance from the face of the Reflexion Filter. The mic capsule should sit roughly level with the front edges of the filter where the curved wall ends.

Having said all that, you CAN use the Reflexion Filter to achieve different effects by experimenting with positioning. Moving the mic into the face of the Reflexion Filter will give a 'darker' and more 'dead' sounding recording, but it will also affect the polar pattern response of the mic, so the mic will perform slightly differently. Again, in most cases this would be undesirable, but this method of use can create some cool results... try mic'ing an electric guitar cab this way, it can sound great!

Moving the mic further away will mean there is more room ambience recorded with the dry source. Again, this is not usually desirable but can be used to get a specific 'room sound' without the room taking over completely!

The Reflexion Filter can be used not only for recording vocals and acoustic guitars etc, but as outlined above, you can experiment to find new applications like the guitar cab mic'ing we suggested above. We'd love to hear from you with your own novel applications, so please contact us via the main web site, www.seeelectronics.com, to let us know what you think of the product, and how you are using it.

Thanks again, and we hope you enjoy the results of your new toy!

James Young

www.seeelectronics.com

T: +44 (0) 1582 470 260
F: +44 (0) 1582 470 269

sales@seeelectronics.com

Unit 23 Westbury Close
Townsend Industrial Estate
Houghton Regis
Beds
LU5 5BL
UK

