

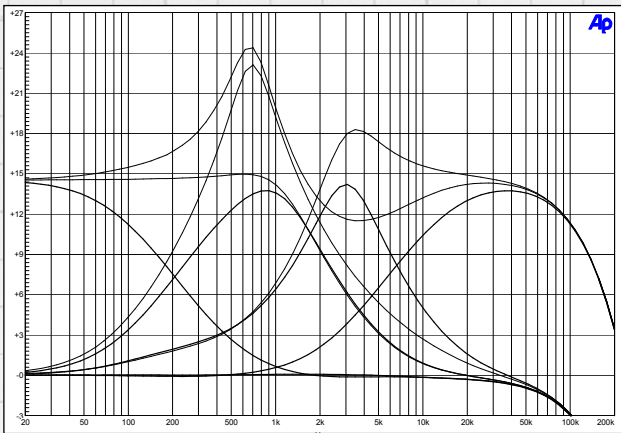

VLZPro vs. VLZ3 An obsessive overview of the VLZ3 advantage

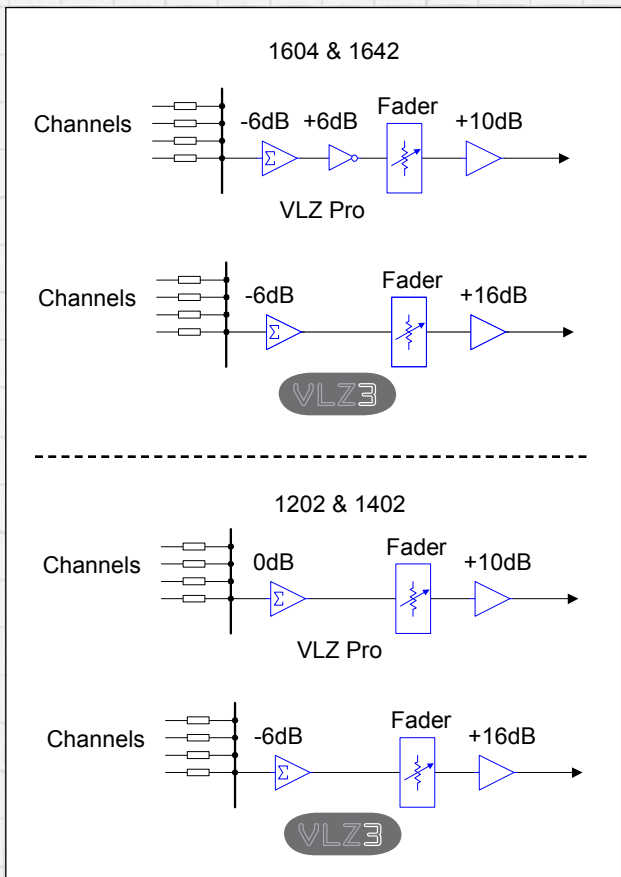

EQ
WHY VLZ3 EQ IS BETTER
 These graphs may look intimidating. But trust us—VLZ3's EQ is more musical and offers more creative control over the full frequency range, thanks to improved interaction of the separate EQ bands.

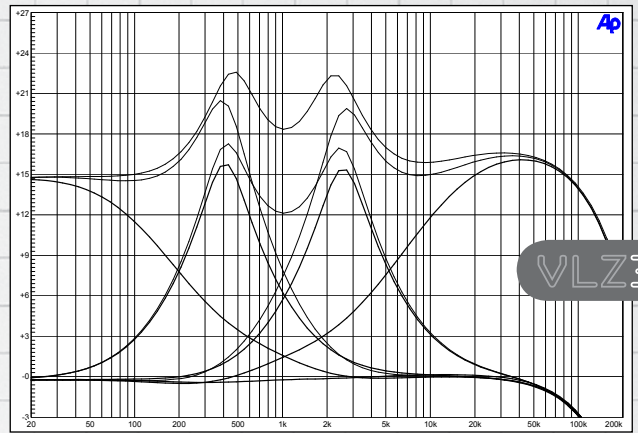

NEGATIVE SUMMING ARCHITECTURE

WHY VLZ3S HAVE MORE HEADROOM AND LESS DISTORTION
 High headroom and low noise have always been hallmarks of Mackie mixers. With the new VLZ3s we're able to get even more headroom and less noise thanks to a better use of negative summing architecture. We mix all signals in the summing amp at -6dB, for lots of headroom right off the bat. Then we add 6dB of gain to the standard 10dB found in the fader gain stage. The net result is the ability to mix more hot signals without distortion.

MIC PRE
WHY XDR2 MIC PRES ARE BETTER
 Our new XDR2 "Extended Dynamic Range" mic preamps have a much wider frequency range, especially in the low end, even at extremely high gain settings.

