

## SPX2000 Key Features

### Superb Sonic Quality with 24bit/96khz Standard Throughout

The heart of SPX2000 hardware is the 96kHz audio DSP, with 32-bit internal processing (58-bit accumulator) which offers abundant processing power for the advanced effect algorithms. The 24-bit 128-times over-sampling AD/DA converters deliver 106dB dynamic range and flat response from 20Hz to 40kHz at 96kHz sampling rate.



Both are in line with the DM series Digital Production Console quality.

### Refined Preset Programs Including the Newly Developed "REV-X" Reverb Algorithm

There are 3 banks to the SPX2000 memory: "PRESET", "CLASSIC" and "USER". "PRESET" bank contains 97 programs. 17 programs are made with the newly developed "REV-X" reverb algorithms. "REV-X" is a whole new generation of Yamaha Reverb programs with the richest reverberation tone and smoothest

decay. There are "REV-X Hall", "REV-X ROOM" and "REV-X PLATE" algorithms. Newly introduced parameters like ROOM SIZE and DECAY envelope also bring much higher definition and finer nuances.

Other 80 presets consist of the popular trademark SPX programs such as gate reverbs, delays, pitch effects, modulation and other special effects. Also the latest algorithms are introduced from the DM series Digital Production Consoles such as Multi-band Dynamic Processors. All programs went through refined editing by the top engineers, and no program is the same as the ones offered in the previous effect processors or digital consoles.

The "CLASSIC" bank on the other hand consists of 25 programs giving you the reminiscence of the original presets from the early SPX models such as SPX90II. "USER" bank can store 99 user programs.

### Reliable and Efficient Front Panel User Interface with Colors

SPX2000 hardware cosmetic is designed to offer optimum reliability for the engineers on site. The rugged aluminum front panel features 2 sets of "Cross-keys" - simple navigation tool anyone is familiar with. Parameters are sorted in 3 groups: "PARAMETER", "FINE PARAM" and "UTILITY" to ensure speedy access. Also other dedicated buttons like UNDO, COMPARE, BANK, MODE, METER, TAP, and BYPASS ensure efficient operations.

SPX2000 LCD offers 5 back light color variations(!). You can freely assign any of the 5 colors to user programs. The preset programs are colored by effect groups giving you an instant recognition of the effect type even from the distance. (CYAN: Reverbs, WHITE: Delays, MAGENTA: Pitch & Modulations, YELLOW: Others, GREEN: CLASSIC Bank) RED is reserved for warning messages.

SPX2000 "OPERATION LOCK" function offers 3 security levels; from preventing accidental changing of Utility settings, or protecting stored memories to prohibiting almost all operations.

### Professional Audio I/O and Control Connectors

SPX2000 Rear Panel houses, for analog connection, XLR type (w/latch) and quarter inch L + R INPUT and OUTPUT connectors both with +4dBu/-10dBu selector switch.

Professional digital connection is secured with AES/EBU XLR type I/O connectors and BNC WORDCLOCK IN connector. Also MIDI IN, OUT/TROUGH and USB TO HOST connectors are provided for remote control and data management using computers, Digital Consoles or any MIDI device. Foot Switch connector for effect tempo control is placed on the front panel.

### "SPX2000 Editor" for Mac OSX and Windows

SPX2000 Editor will give you the editing, data management, and remote control capability using computers, in the same environment and common interface as the STUDIO MANAGER for Yamaha Digital Consoles.

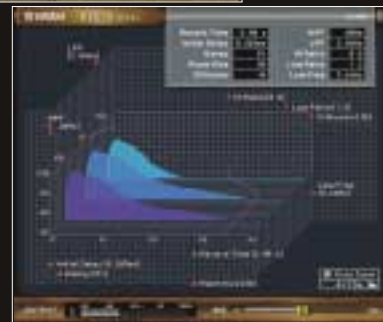
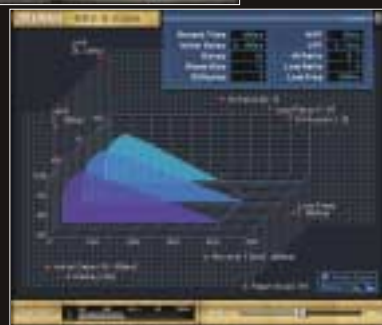
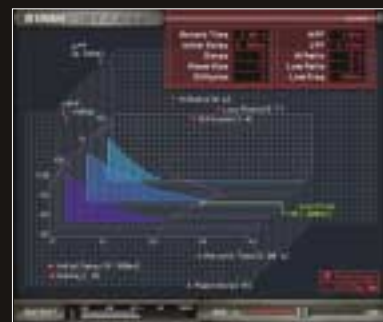

The SPX2000 Editor will be available for downloading from December, 2003 at the Yamaha website (<http://www.yamahaproaudio.com>).

# SPX2000

## PROFESSIONAL MULTI-EFFECT PROCESSOR

### ANALOG I/O CHARACTERISTICS

Terminal	Level SW	Input Level VR.	Actual Load Impedance	For Use with Nominal	Level		Connector
					Nominal	Max before Clip	
INPUT [L,R]	+4dBu	Nominal: 0dBu	10kΩ	600Ω Lines	+4dBu (1.23V)	+24dBu (12.28V)	XLR-3-31 type (Balanced)
	-10dBu				-10dBu (0.245V)	+10dBu (2.45V)	Phone Jack (TRS: Balanced)
OUTPUT [L,R]	+4dBu	-	150Ω	600Ω Lines	+4dBu (1.23V)	+24dBu (12.28V)	XLR-3-32 type (Balanced)
	-10dBu				-10dBu (0.245V)	+10dBu (2.45V)	Phone Jack (TRS: Balanced)

\*0dBu = 0.775Vrms

### GENERAL SPECIFICATIONS

AD/DA Conversion	24-bit Liner 128-times Oversampling (@fs=44.1,48kHz)
	24-bit Liner 64-times Oversampling (@fs=88.2,96kHz)
Sampling Frequency	Internal Clock: 44.1, 48, 88.2, 96kHz
	External Clock: Normal Rate:39.69kHz - 50.88kHz, Double Rate: 79.38kHz - 101.76kHz
Frequency Response	20Hz - 20kHz (0dB +1.0, -3.0)@48kHz
	20Hz - 40kHz (0dB +1.0, -3.0)@96kHz
Dynamic Range	106dB AD + DA, Input Level VR: Max
Total Harmonic Distortion	fs=96kHz, 0.01%@1kHz
Bank Memory	PRESET BANK: 97, USER BANK: 99, CLASSIC BANK: 25
Displays	LCD: 16 characters x 2 lines with 5-color Back Light, METER LED: 12 segment (L,R)
Dimension & Weight	480W x 45H x 372.5D mm, 4kg
Power Requirements	UC: AC 120V, 60Hz CE: AC 230V, 50Hz
Power Consumption	25W
Option	Foot Switch FC5

### DIGITAL I/O CHARACTERISTICS

Terminal	Format	Data Length	Level	Connector
AES/EBU IN	AES/EBU	24bit	RS422	XLR-3-31 type (Balanced)
AES/EBU OUT	AES/EBU	24bit	RS422	XLR-3-32 type (Balanced)

### CONTROL I/O CHARACTERISTICS

Terminal		Format	Level	Connector
USB	TO HOST	USB 1.1	0-3.3V	B type USB Connector
MIDI	IN	MIDI	-	DIN Connector 5P
	OUT/THRU	MIDI	-	DIN Connector 5P
WORD CLOCK	IN	-	TTL/75Ω	BNC Connector

### OPTION

FOOT SWITCH  
FC5



# SPX2000

## PROFESSIONAL MULTI-EFFECT PROCESSOR



### The New Generation SPX with 96kHz Audio and brand new "REV-X" Reverb Algorithm

The name "SPX" has been synonymous with "professional multi-effect processor" for more than 15 years, and the models like SPX90, SPX90II, SPX900, SPX1000 and SPX990 have been the most commonly found equipment in the studio and SR racks.

The SPX2000, while inheriting the standard interface and common programs from its predecessors, brings a new dimension to the sound quality with the new "REV-X" reverb algorithm and the 96kHz audio DSP. It also offers advanced user interface like 5 assignable LCD back colors, operation lock mode and computer based editor program. SPX2000 is the new generation equipment in line with the DM series Digital Production Consoles, and is suitable for broad range of applications, from Live SR to production studios where professional quality effect processing is required.

YAMAHA CORPORATION  
P.O.BOX 1, Hamamatsu Japan

<http://www.yamahaproaudio.com>



This document is printed on chlorine-free (ECF) paper with soy ink.



CREATING 'KANDO' TOGETHER

'KANDO' ...Inspiring the Heart and Spirit.

LPA479 Printed in Japan

# SPX2000 Effect Programs

## REVERB AND EARLY REFLECTION

The SPX2000 has a wide variety of uncompromising, superior reverb and spacial ambience effects, including ER (early reflection). These provide not only exceptionally natural real-world ambience but a stunning selection of other-worldly effects as well.

The REV-X presets in particular—all 17 of them—were redesigned completely from the ground up, with new reverb algorithms. The Hall presets (#1 - 7) provide various natural, high-density reverb programs, while the Plate programs (#16 - 18) give you a crisp, well-defined sound—perfect for vocals. The seven Room presets (#27 - 33) feature realistic recreations of various environments, with fine parameter control over room size, as well as a variety of wall materials and sound-absorption characteristics.

Each and every one of these programs boasts incredibly rich tone and a super-smooth, grain-free decay—giving you authentic ambience for enhancing the original sound. Moreover, various parameters provide detailed, comprehensive control over the processed sound.

- The SPX2000 also features: Stereo Reverb, Gate Reverb and special Drum Machine Reverb programs—refined and updated from the SPX990.
- ER group effects especially for enhancing drums, percussion and guitar, as well as creating powerful, in-your-face sounds. These include #34 Fat Reflections, #41 Full Metal Gate (a dynamic gated reverb program), and #42 Reverse Gate.
- The Classic bank offers 4 basic reverbs—Hall, Room, Vocal and Plate, as well as the early reflection, gate reverb and reverse gate programs from the early SPX models.

## DELAY AND ECHO

The Delay/Echo presets feature versatile, high-quality delay effects—allowing you to tap out a tempo for the delay time with the [TAP] button or a footswitch, or synchronize the SPX2000 to the tempo and note values from an external MIDI device.

A full selection of delays is provided, with mono, stereo, and a special stereo with center channel (#50, Delay L, C, R) for creating three-dimensional ambience. There's also a Stereo Phasing preset (#66) that allows you to modulate the delay sound with a sine or triangle wave for complex, unique delay effects.

The Classic bank also offers two popular programs from the early SPX models: Delay L, R and Stereo Echo.

## PITCH CHANGE

These programs give you sophisticated, high-quality pitch shift effects at your fingertips, updating the original SPX programs with enhanced sound, greater musical control and dynamic expressiveness. The new effects have many functions such as mixing of the sounds, feedback, and synchronizing to tempo. The Classic bank includes Pitch effects from the early SPX models, giving you MIDI note control over the pitch change.

## MODULATION

A wide variety of modulation effects are included on the SPX2000—for fattening the sound, enhancing it, giving it animation and depth, or completely transforming it. Programs include Flanger, Phaser, Chorus,

Symphonic, Tremolo, Auto Pan, Ring Modulation and Modulation Filter. The Rotary Speaker program (#71) faithfully recreates that rich rotating speaker sound for organ and other instruments. Special Dynamic Modulation programs, such as Dyna Flange (#76) and Dyna Phaser (#77), let you vary, respectively, the delay time and the frequency of the effect sound with the dynamics of your playing or MIDI velocity—for even greater expressive control. Also included are combination programs such as #62 Reverb + Symphonic, gives you Yamaha's original multiple chorus effect with modulated delay time, and a high-quality reverb. Preset #64 Chorus + Reverb also lets you use both chorus modulation and reverb simultaneously.

The Classic bank features the original modulation programs of early SPX models.

## FILTER

These new programs include Dynamic Filter, Multi Filter and Multi-band Dynamic Processor. Program #78 Dyna Filter gives you powerful control over the sound by allowing you to vary the central frequency of the filter with the signal itself or via MIDI velocity. The Multi-band Dynamic Processor is also exceptionally versatile, giving you independent control over the dynamic range for three separate frequency bands—each with an expander/compressor/limiter—allowing you to create extremely fat, full and rich sounds.

## DISTORTION

The SPX2000 also has your distortion bases covered, with an Amp Simulator effect (#83) for recreating vintage guitar amps, and a

special new Distortion program (#82) featuring five different distortion characteristics (DST1/DST2/OVD1/OVD2/CRUNCH), a noise gate, and comprehensive control over the tone. The SPX2000 also has combination effect programs, #84 Distortion → Flanger and #85 Distortion → Delay, letting you combine distortion with modulation or delay effects for an even wider sonic palette.

## COMBINATION EFFECTS

A variety of multi effect programs give you even greater signal processing flexibility and creativity, putting reverb and modulation together, or combining delay with ambience. These combination effects are provided in two different types, one routing the signal in parallel (for example, #94 Delay + Reverb), the other using serial processing of the signal (for example, #95 Delay → Reverb).

## FREEZE

The Freeze effect turns the SPX2000 into a phrase sampler, ideal for looping parts during live performance. Quality is exceptionally high (96 kHz), even for long phrases up to nearly 3 seconds. The sampled audio can be played by pressing a panel button or by using an external MIDI trigger. You can even specify the number of playback repeats, up to 100 and shift the pitch of the sample (in semitones). The Classic bank brings 2 programs from the early SPX models. Preset #23 Freeze A lets you set the start and end points, while #24 Freeze B allows you to finely change the playback pitch of the sample in 1-cent units (1/100 semitone).

### PRESET BANK

No.	EFFECT NAME	CLASSIFICATION	LCD COLOR
1	REV-X LARGE HALL	HALL	CYAN
2	REV-X MED HALL		
3	REV-X SMALL HALL		
4	REV-X TINY HALL		
5	REV-X WARM HALL		
6	REV-X BRITE HALL		
7	REV-X HUGE HALL		
8	AMBIENCE		
9	STEREO HALL		
10	VOCAL CHAMBER		
11	BRIGHT HALL		
12	BREATHY REVERB		
13	CONCERT HALL		
14	REVERB FLANGE		
15	REVERB STAGE		
16	REV-X VOCAL PLT	PLATE	
17	REV-X BRIGHT PLT		
18	REV-X SNARE PLT		
19	VOCAL PLATE		
20	ECHO ROOM 1		
21	ECHO ROOM 2		
22	PRESENCE REVERB		
23	ARENA	ROOM	
24	THIN PLATE		
25	OLD PLATE		
26	DARK PLATE		
27	REV-X CHAMBER		
28	REV-X WOOD ROOM		
29	REV-X WARM ROOM		
30	REV-X LARGE ROOM		
31	REV-X MED ROOM		
32	REV-X SMALL ROOM		
33	REV-X SLAP ROOM		
34	FAT REFLECTIONS		
35	BIG SNARE		
36	BAMBOO ROOM		
37	REFLECTIONS		
38	STONE ROOM		
39	CONCRETE ROOM		
40	REVERSE PURPLE	GATE REVERB	
41	FULL METAL GATE		
42	REVERSE GATE		
43	DRUM MACH. AMB S	DRUM MACHINE REVERB	
44	DRUM MACH. AMB L		
45	ELECT. SNR PLAT		
46	MONO DELAY	DELAYS	WHITE
47	120 BPM MONO DDL		
48	120 BPM X-DDL		
49	STEREO DELAY		
50	DELAY LCR		
51	KARAOKE ECHO	PITCH EFFECTS	MAGENTA
52	GOOD OL P.CHANGE		
53	VOCAL SHIFT		
54	STEREO PITCH		
55	PITCH SLAP		
56	HALO COMB		
57	GRUMPY FLUTTER	MODULATION	
58	ROGER ON THE 12		
59	BOTTOM WHACKER		
60	VOICE DOUBLER		
61	SYMPHONIC		
62	REV+SYMPHONIC		
63	DETUNE CHORUS		
64	CHORUS & REVERB		
65	BASS CHORUS		
66	STEREO PHASING		
67	CLASSY GLASSY		

### CLASSIC BANK

No.	EFFECT NAME	LCD COLOR
1	REV1 HALL	GREEN
2	REV2 ROOM	
3	REV3 VOCAL	
4	REV4 PLATE	WHITE
5	EARLY REF1	
6	EARLY REF2	
7	DELAY LR	
8	STEREO ECHO	
9	STEREO FLANGE A	
10	STEREO FLANGE B	
11	CHORUS A	
12	CHORUS B	
13	STEREO PHASING	
14	TREMOLO	
15	SYMPHONIC	
16	GATE REVERB	
17	REVERSE GATE	
18	REVERB & GATE	YELLOW
19	PITCH CHANGE A	
20	PITCH CHANGE B	
21	PITCH CHANGE C	
22	PITCH CHANGE D	
23	FREEZE A	GREEN
24	FREEZE B	
25	PAN	

### 5 COLOR LCD PRESET ASSIGNMENT

REV-X LARGE HALL REV TIME= 4.00s	CYAN REVERB & ER
STEREO DELAY DELAY L= 250.0ms	WHITE DELAY & ECHO
GOOD OL P.CHANGE PITCH 1 = 0	MAGENTA PITCH CHANGE & MODULATION
M. BAND DYNA LOW GAIN= +3.0dB	YELLOW FILTER, DISTORTION, MULTIPLE & FREEZE
REV 1 HALL REV TIME= 2.6s	GREEN CLASSIC BANK

### REV-X PARAMETER LIST

	PARAMETER	Range	Description
BASIC PARAMETER	REV TIME	0.10-46.92s	Determines the amount of time until the reverberation decays to silence.
	HI.RATIO	0.1-1.0	Determines the reverberation length (release time) for the high and low frequency sounds. This is used to simulate the damping factor of walls and ceiling.
	LO.RATIO	0.1-1.4	Determines the reverberation length (release time) for the high and low frequency sounds. This is used to simulate the damping factor of walls and ceiling.
	INI.DLY	0.0-125.0ms	Determines the time that elapses between the original sound and the reverberation.
FINE PARAMETER	DIFF.	0-10	Determines the density and separation of the reverberation.
	ROOMSIZE	0-28	Determines the virtual 'size' of the room, and affects the reverb time.
	MIX BAL.	0-100%	Determines the level balance of the original (dry) sound and the processed (wet) sound.
	OUT LVL	0-100%	Determines the overall level of the mixed original and processed sound.
	HPF	Thru, 22.0Hz-8.00kHz	Cuts the low frequencies of the processed sound.
	LPF	1.00-18.0kHz, Thru	Cuts the high frequencies of the processed sound.
	LO.FREQ.	22.0Hz-18.0kHz	Basic frequency for the LO.RATIO parameter.
	DECAY	0-53	Determines the shape of the reverberation envelope. This affects the 'color' of the reverberation.

### SPX2000 Block Diagram

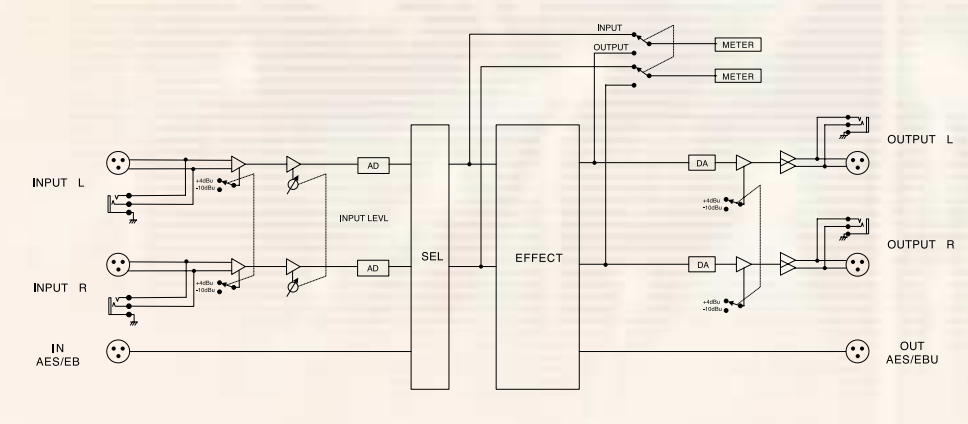

### Dimensions

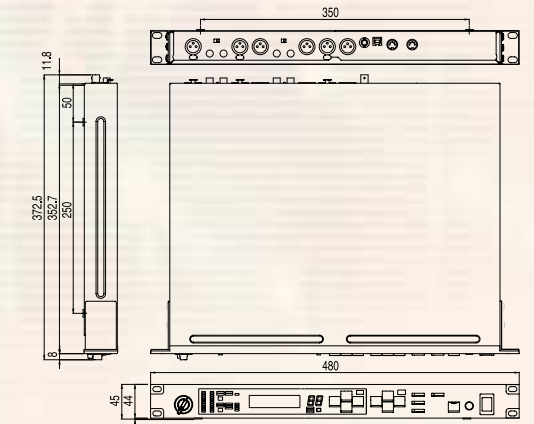

### Rear Panel



# SPX2000

## PROFESSIONAL MULTI-EFFECT PROCESSOR

