

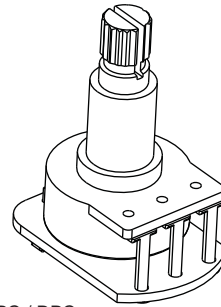

0230-0160A

PO BOX 4394  
SANTA ROSA, CA  
95402 USA

P (707) 525-9941  
F (707) 575-7046  
EMGPICKUPS.COM



SPC / RPC

## INSTALLATION INFORMATION

### EMG MODELS: SPC / RPC (ACTIVE/PASSIVE PICKUP INPUTS)

#### SPECIFICATIONS

|                           |         |
|---------------------------|---------|
| Input Impedance (Ohms)    | 250K    |
| Input Referred Noise      | -130dbV |
| Output Impedance (Ohms)   | 2K      |
| Current @ 9V (Microamps)  | 980     |
| Battery Life (Hours)      | 250     |
| Maximum Supply (Volts DC) | 18      |

#### INCLUDED:

- 1 SPC or RPC Control
- 1 Battery Clip with Buss Connector
- 1 Stereo Output Jack (Battery Switching)
- 2 Interconnect cables

#### GENERAL OPERATION:

The SPC and RPC are active EQ circuits for guitar. The SPC is a mid-range boost. The RPC is a low cut/high boost.

The graphs below illustrate the effects of the controls. The thick black line displays the effect with the control all the way up (clockwise).

The flat black line illustrates the effect with the control all the way down (counter-clockwise) in the bypass mode. The controls are continuously variable from flat to maximum effect. The SPC and RPC are wired in series with the signal path, so there is an input and output.

Both controls feature buffered inputs and can be used with passive pickups.

#### Frequency Response: EMG-SPC

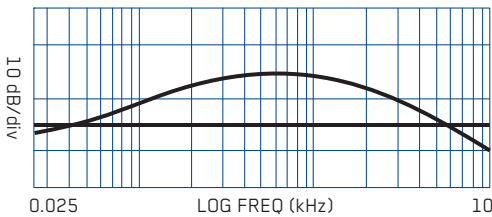

#### EMG-RPC

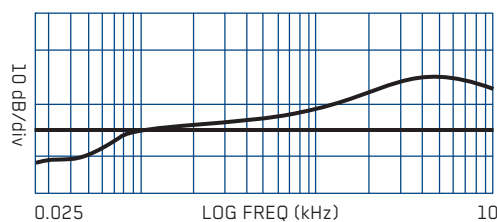

#### Dimensions:

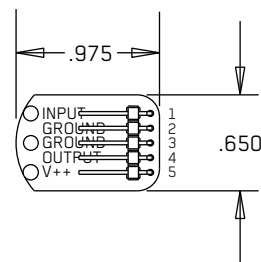
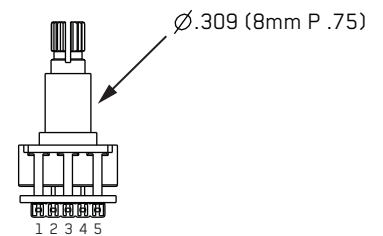
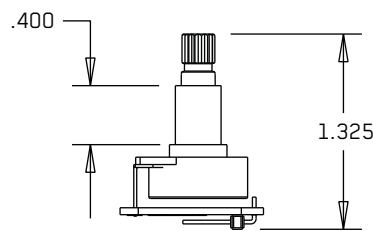

Connector for EMG Active Tone controls and accessories.

- Pin 1 Input
- Pin 2 Ground for Input
- Pin 3 Ground for Output
- Pin 4 Output
- Pin 5 V+ Supply

#### WARRANTY

All EMG Pickups and accessories are warranted for a period of two years. This warranty does not cover failure due to improper installation, abuse or damage. If upon examination the pickup is determined to be defective, a replacement will be made. Warranty replacement products are covered by this same warranty. This warranty covers only those pickups and accessories sold by authorized EMG Dealers. This warranty is not transferable.

**Installation Instructions:**  
**EMG Models: SPC and RPC**

Like all EMG Accessory products, the SPC and RPC use a 5-pin connector. Diagram #1 to the right shows how the plug-in connectors are installed. Be sure to reverse the input connector as shown.

Since there are a variety of installations in which the SPC or RPC can be installed it is impossible to show every installation in this data sheet. Some of the simpler installations have been chosen. More diagrams are available at our website <http://www.emgpickups.com>. Diagrams #2 and #3 illustrate installations that have a single pickup and do not use a selection switch.

Page 3 has diagrams that have 2 pickups and a selection switch.  
 Page 4 has diagrams that have 3 pickups and use the B161v4 five position selection switch/buss. If you have the B161v4, refer to that data sheet where more options regarding the 3-pickup instruments are available.

Keep in mind that all of the EMG Accessory controls can be substituted for one another since they all have buffered inputs and utilize the same 5-pin connector. So, if you decide you would rather use the EXG instead of the SPC, simply unplug the SPC and replace it with the EXG.

All of the EMG Active controls use the same 5-pin connector shown below.

Note: Reversed connector! Pins 1 and 2 are reversed. Make sure the connectors are plugged on as shown.

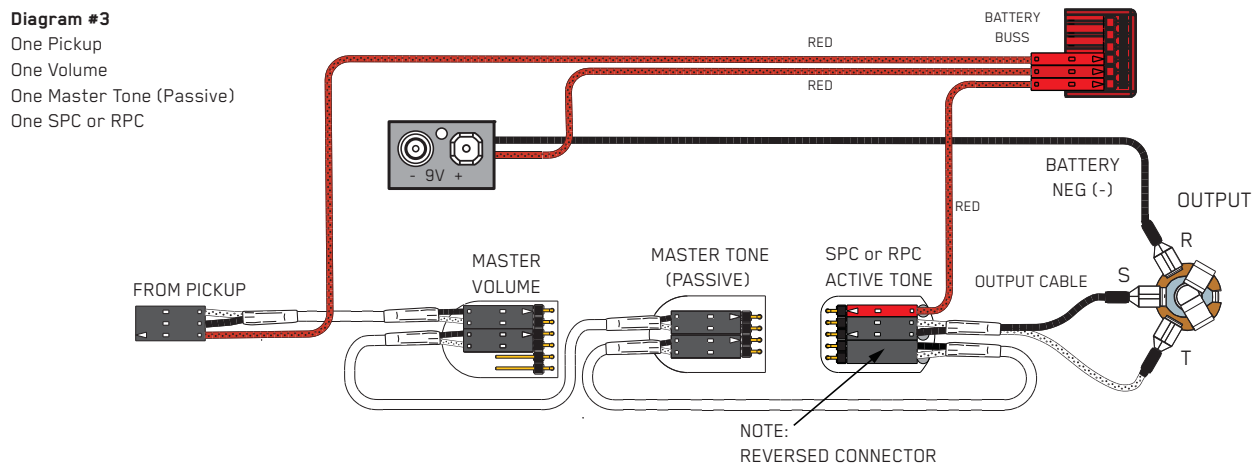
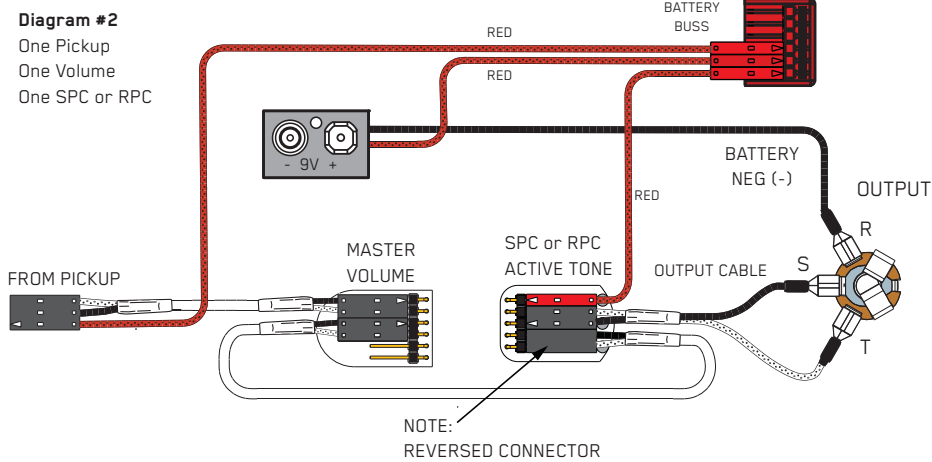
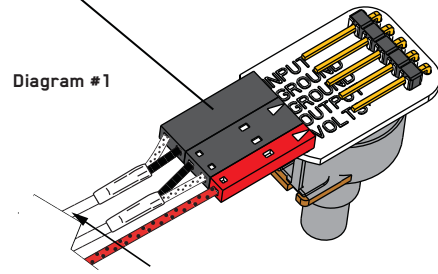

**Powering up the pickups:**

If your existing active pickup cables don't have the connector for the power buss, simply use some needle nose pliers and pull out the V+ header and solder the RED Wires of the EMG Pickups to any of the pins on the header. Also, don't forget to solder the RED Wire of the battery clip to one of the header pins of the buss as well.

If you are installing EMG-HZ Passive Pickups refer to their diagrams. The Red Wire of the HZ Pickup is NOT for battery power, it is a coil wire.

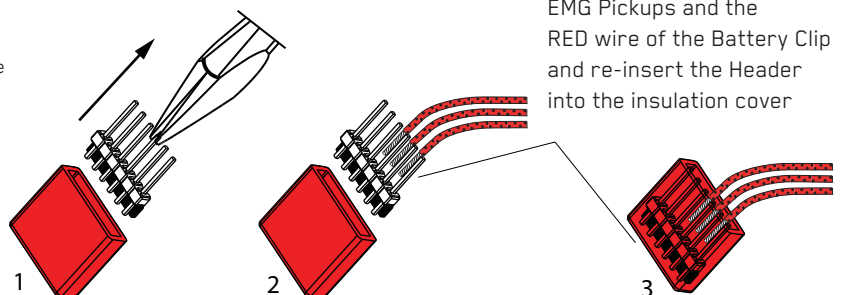

Solder RED wires from both EMG Pickups and the RED wire of the Battery Clip and re-insert the Header into the insulation cover

## 2 Pickup Guitars using a selection switch:

Diagrams #4 and #5 show the pickups connected to the B157 Pickup Buss. To learn more about the B157 Pickup Buss, be sure to go to the EMG Website: <http://www.emgpickups.com>. More diagrams are available at the EMG website. The SPC or any EMG Active Tone Control is shown following the pickup buss and then to the output jack. A master volume could easily follow the SPC before the output jack.

### Diagram #4

2 Pickups  
Toggle Style Switch  
Volume each Pickup (Volumes are independent)  
SPC or RPC Control

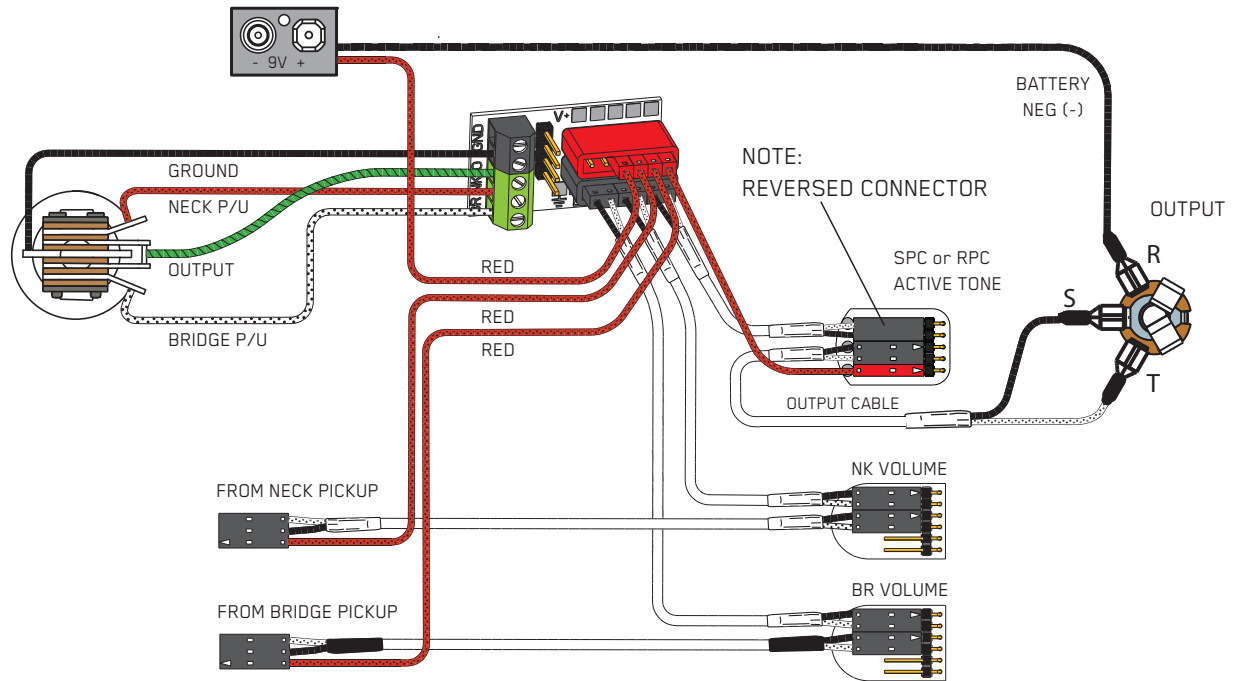

### Diagram #5

2 Pickups  
Toggle Style Switch  
Volume each Pickup (Volumes are independent)  
Master Tone (Passive)  
SPC or RPC Control

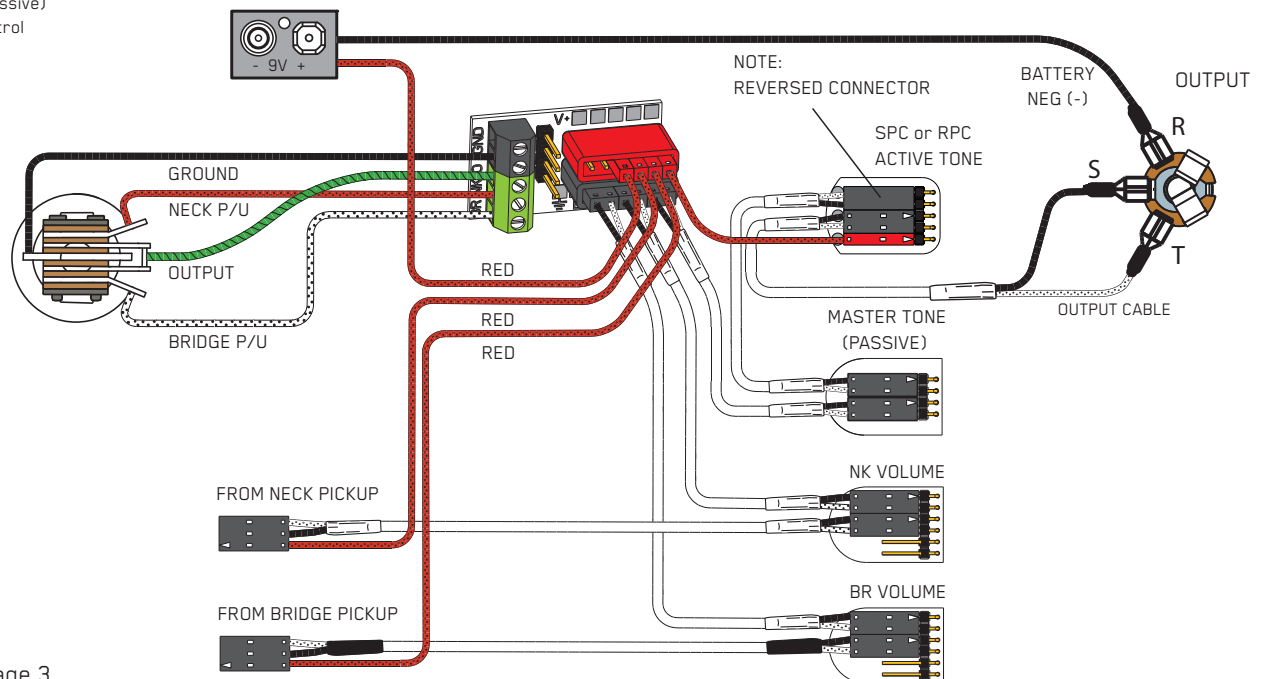

### 3 Pickup Guitars using a selection switch:

Diagrams #6, #7 show a typical installation with a Volume/Tone/SPC in a "daisy-chain" series wiring. The only difference between the diagrams is the order in which the controls are wired. The diagrams yield the same results. The diagrams have been edited to show the SPC input, output, and power (9V+). The pickup inputs, battery, and "ring" contact to the jack have been omitted for clarity.

All diagrams show the B161 5-Position switch buss. To learn more about the B161 5-Position switch Buss, go to the EMG Website: <http://www.emgpickups.com>.

#### Refer to Diagram #6

Start by installing the SPC or RPC as shown in Diagram #6.

- 1) Plug a coax cable from the output switch to the Volume control.
- 2) Plug a coax cable from the Volume control to the Tone control.
- 3) Plug a coax cable from the Tone control to the input of the SPC.
- Be sure to reverse the connector on the input of the SPC as shown.
- 4) Plug the output cable from the SPC to the output jack.
- 5) Plug the Red wire from the SPC to one of the supply pins on the B161 Switch Buss.

Be sure the 3 shunts are installed on the bypass header of the B161 switch or you won't get any output from the guitar.

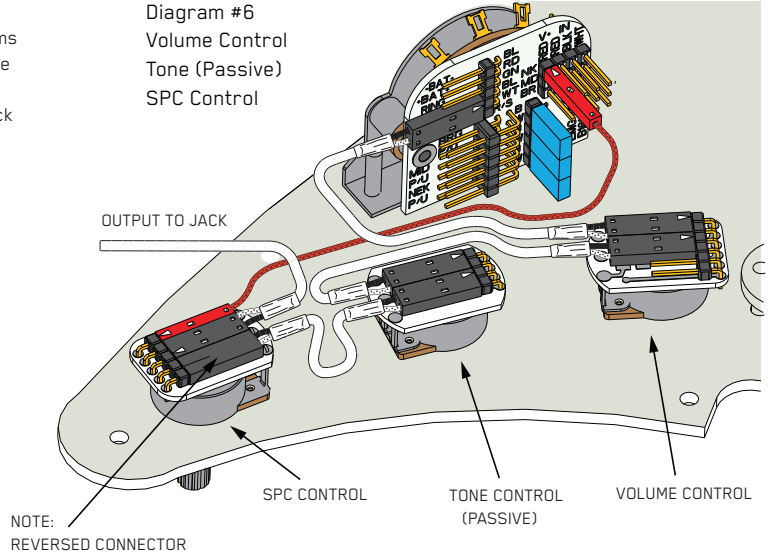

Diagram #6  
Volume Control  
Tone (Passive)  
SPC Control

NOTE:  
REVERSED CONNECTOR

#### Refer to Diagram #7

Start by installing the SPC or RPC as shown in Diagram #7.

- 1) Plug a coax cable from the output switch to the Tone control.
- 2) Plug a coax cable from the Tone control to the input of the SPC.
- Be sure to reverse the connector on the input of the SPC as shown.
- 3) Plug a coax cable from the output of the SPC to the Volume control.
- 4) Plug the output cable from the Volume control to the output jack.
- 5) Plug the Red wire from the SPC to one of the supply pins on the B161 Switch Buss.

Be sure the 3 shunts are installed on the bypass header of the B161 switch or you won't get any output from the guitar.

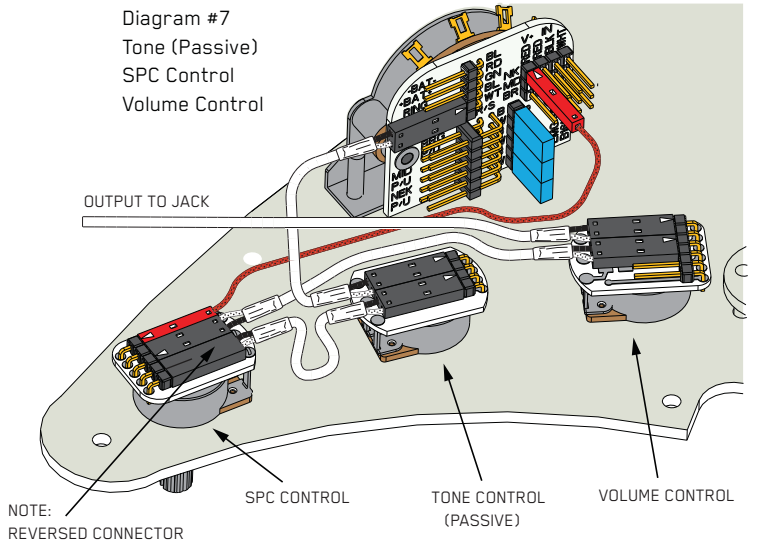

Diagram #7  
Tone (Passive)  
SPC Control  
Volume Control

NOTE:  
REVERSED CONNECTOR

#### Refer to Diagram #8

Diagram #8 shows 2 active controls installed: SPC and VLPF. This is the same as the X Series Pickups that use an active tone (VLPF) and adding the SPC Control.

- 1) Plug a coax cable from the output switch to the Volume control.
- 2) Plug a coax cable from the Volume control to the input of the VLPF.
- Be sure to reverse the connector on the input of the VLPF as shown.
- 3) Plug a coax cable from the output of the VLPF to the input of the SPC.
- Be sure to reverse the connector on the input of the SPC as shown.
- 4) Plug the output cable from the SPC to the output jack.
- 5) Plug the Red wires from both the VLPF and SPC to the extra 9V+ supply pins on the B161 Switch Buss.

Be sure the 3 shunts are installed on the bypass header of the B161 switch or you won't get any output from the guitar.

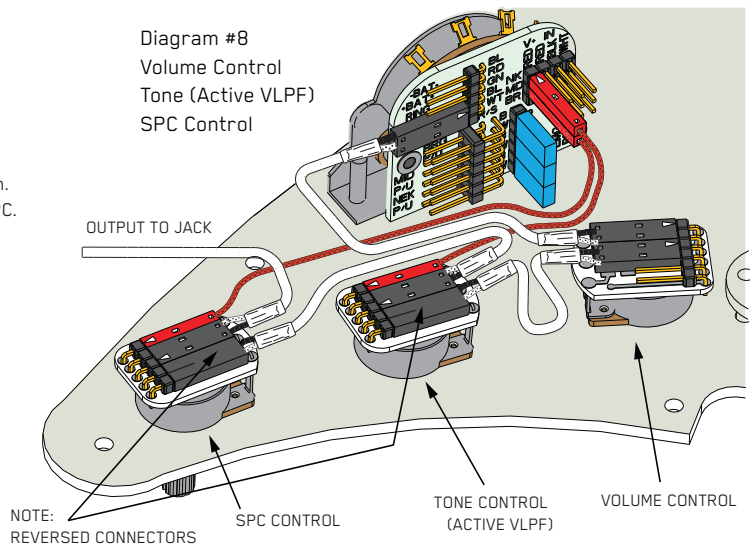

Diagram #8  
Volume Control  
Tone (Active VLPF)  
SPC Control

NOTE:  
REVERSED CONNECTORS