

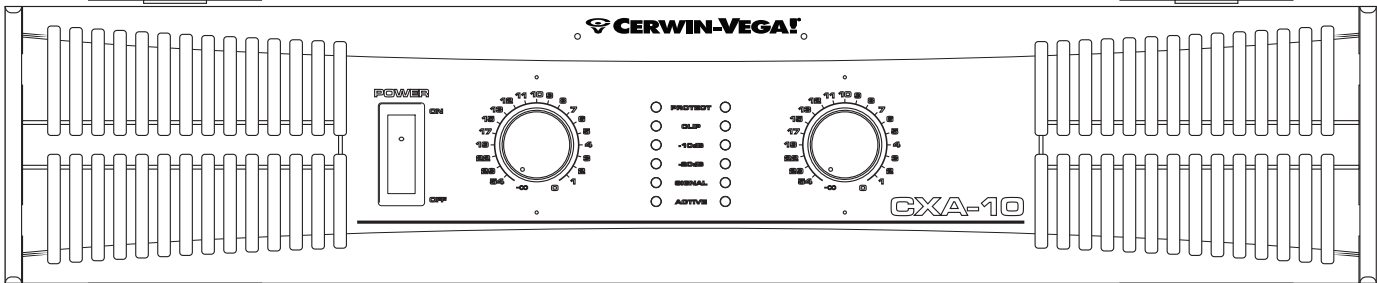

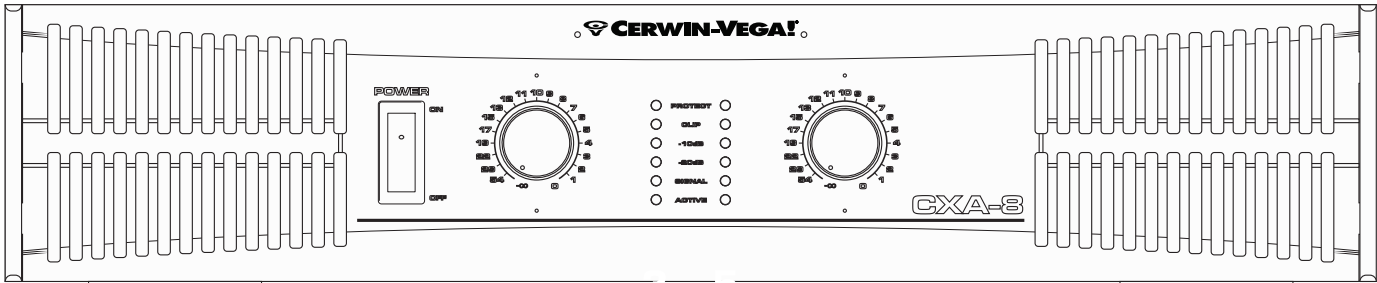

CERWIN-VEGA!

CXA-8 & CXA-10 AMPLIFIERS

OPERATION MANUAL



WARNING

1. Read these instructions - All the safety and operating instructions should be read before this product is operated.
2. Retain these instructions - The safety and operating instructions should be retained for future reference.
3. Heed all warnings - All warnings on the appliance and in the operating instructions should be adhered to.
4. Follow all instructions - All operating and use instructions should be followed.
5. Do not use this apparatus near water - The appliance should not be used near water or moisture - for example, in a wet basement or near a swimming pool, and the like.
6. Clean only with dry cloth.
7. Do not block any ventilation openings. Install in accordance with the manufacturer's instructions.
8. Do not install near any heat sources such as radiators, heat registers, stoves, or other apparatus (including amplifiers) that produce heat.
9. Do not defeat the safety purpose of the polarized or grounding plug. A polarized plug has two blades with one wider than the other. A grounding plug has two blades and a third grounding prong. The wide blade or the third prong is provided for your safety. If the provided plug does not fit into your outlet, consult an electrician for replacement of the obsolete outlet.
10. Protect the power cord from being walked on or pinched particularly at the plugs, convenience receptacles, and at the point where they exit from the apparatus.
11. Only use attachments/accessories specified by the manufacturer.
12. Use only with the cart, stand, tripod, bracket, or table specified by the manufacturer, or sold with the apparatus. When a cart or rack is used, use caution when moving the cart/apparatus combination to avoid injury from tip-over. 
13. Unplug the apparatus during lightning storms or when unused for long periods of time.
14. Refer all servicing to qualified personnel. Servicing is required when the apparatus has been damaged in any way, such as power supply cord or plug is damaged, liquid has been spilled or objects have fallen into the apparatus, has been exposed to rain or moisture, does not operate normally, or has been dropped.
15. Please keep the unit in a good ventilation environment.
16. **WARNING:** To reduce the risk of fire or electric shock, do not expose this apparatus to rain or moisture. The apparatus shall not be exposed to dripping or splashing and that no objects filled with liquids, such as vases, shall not be placed on apparatus.
17. **WARNING:** The mains plug or appliance inlet is used as disconnect device, the disconnect device shall remain readily operable.
18. Power Sources – This product should be operated only from the type of power source indicated on the rating label. If you are not sure of the type of power supply to your home, consult your product dealer or local power company. For products intended to operate from battery power, or other sources, refer the operating instructions.
19. Safety Check – Upon completion of any service or repairs to this product, ask the service technician to perform safety checks to determine that the product is in proper operating condition.
20. Don't touch conductive parts of output terminals to prevent hazardous electrical shock. The external wiring connected to the terminals requires installation by an instructed person or the use of ready-made leads or cords.
21. This equipment is for commercial & professional use only.
22. This product is in compliance with EU WEEE regulations. Disposal of end of life product should not be treated as municipal waste. Please refer to your local regulations for instructions on proper disposal of this product. 
23. To prevent hazardous electrical shock, do not touch the conductive parts of the output terminals. The external wiring connected to the terminals requires installation by a qualified technician or the use of ready-made leads or cords. 
24. Please locate the apparatus at places nearby power socket for quick power disconnection in emergency.



Protective earthing terminal. The apparatus should be connected to a mains socket outlet with a protective earthing connection.



This lightning flash is intended to alert the user to the presence of non-insulated “dangerous voltage” on the output terminals that may be of sufficient magnitude to constitute a risk of electric shock. The external wiring connected to the terminals requires installation by an instructed person or the use of ready-made leads or cords.



CAUTION
RISK OF ELECTRIC SHOCK
DO NOT OPEN



CAUTION: To reduce the risk of electric shock, do not remove any cover. No user-serviceable parts inside. Refer servicing to qualified service personnel only.



The lightning flash with arrowhead symbol within the equilateral triangle is intended to alert the user to the presence of uninsulated “dangerous voltage” within the product's enclosure that may be of sufficient magnitude to constitute a risk of electric shock.



The exclamation point within the equilateral triangle is intended to alert the user to the presence of important operation and maintenance (servicing) instructions in the literature accompanying this appliance.

CAUTION: To prevent electric shock, do not use this polarized plug with an extension cord, receptacle or other outlet unless the blades can be fully inserted to prevent blade exposure.

Cerwin-Vega! CXA-8 & CXA-10 AMPLIFIERS

1. INTRODUCTION

Congratulations! Welcome to the Cerwin-Vega! family. You've joined a growing group of audio professionals who have turned to Cerwin-Vega! for the most advanced audio reproduction systems available. All Cerwin-Vega! systems are thoroughly tested to insure that they meet or exceed our performance specifications. Backed by the best service in the industry, Cerwin-Vega! is dedicated to quality and reliability. For a complete overview of Cerwin-Vega! products, accessories, and services, log onto www.cerwin-vega.com.

2. UNPACKING & INSTALLATION

Although it is neither complicated to install, nor difficult to operate your amplifier, a few minutes of your time are required to read this manual for a properly wired installation, and to become familiar with the unit's features. Please take great care in unpacking the unit and do not discard the carton and other packing materials. They may be needed when moving the unit and are required if it ever becomes necessary to return the unit for service. Never place the unit near a radiator, in front of heating vents, in direct sunlight, in excessive humidity, or dusty locations to avoid damages and to guaranty a long reliable use. Connect the unit with the system components according to the description on the following pages.

3. ABOUT THE CERWIN-VEGA! CXA-8 & CXA-10 AMPLIFIERS

The Cerwin-Vega! CXA-8 & CXA-10 high performance stereo and bridgeable power amplifiers are for those that want to sound like a pro! These home-use versions of the renowned Cerwin-Vega! Professional series amplifiers. The same capability for shock and awe, but with input/output connections and a form factor suited for performing at home versus on stage.

These workhorses have the muscle to accommodate the most demanding audio challenges. With power ratings of up to 1800 watts* (for the CXA-8) and 2800 watts* (for the CXA-10), exceptional THD (Total Harmonic Distortion) and Signal-to-Noise ratings, the CV Series power amps are the right choice for a wide range of music and home theater applications.

To ensure reliable operation the CXA amps include a highly efficient variable speed tunnel cooling system that dynamically follows amplifier output levels. The 21-position detent level control knobs help you set and maintain volume settings. Signal and clip indicators provide a convenient way to monitor the amplifier's status. Proven professionally -- the CXA-8 & CXA-10 Amps are right for the job – even when the “job” is entertaining friends and family.

Main Features:

- Power ratings up to 2800 watts – run in stereo or bridged
- Professional quality design and reliability
- Flow-through cooling design prevents overheating
- Defeatable limiter and high pass filter per channel
- Detented 21-position input level control knobs
- Front panel LED indication of power, clip protect and signal status

Cerwin-Vega! CXA-8 & CXA-10 AMPLIFIERS

CXA AMPLIFIER FRONT PANEL DESCRIPTION

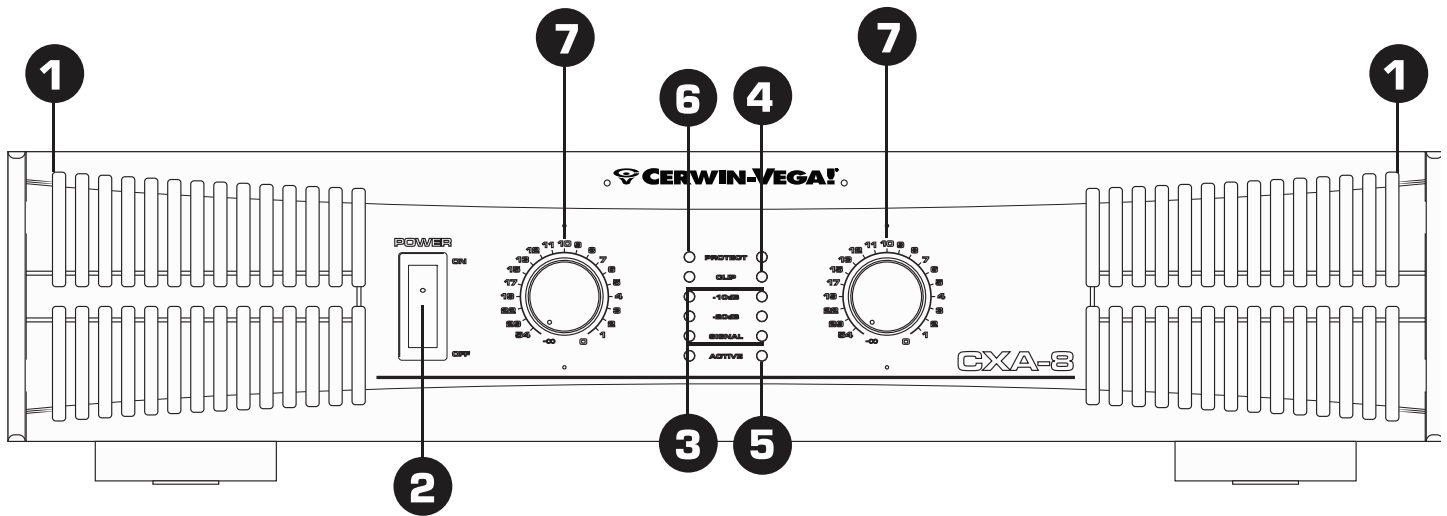

Figure 1.1

1. Fan Vent

The CXA-8 & CXA-10 amplifiers are cooled by two rear-mounted fans. Cool air flows through the front fan filters, reducing the temperature of internal components while forcing the heat out the rear vents. Never block these vents and keep them clean at all times.

2. AC Power Switch

This switch powers the unit on and off.

3. Signal Indicators

These blue LED's will illuminate to indicate that a signal is present at the amplifier input, and that the signal is being amplified.

4. Clip Indicators

These red LED's will illuminate at the clipping threshold. These lights should not light up during normal use as they indicate signal outside of the amplification range of the amplifier. When a signal is "clipped" and the clip indicator illuminates, it means that the signal is being distorted at the output stage. Prolonged clipping can not only damage your amplifier, but also your speakers, so be careful to monitor the clip indicator during setup and use. If the clip indicator is illuminated then simply lower the channel gain or input signal until the indicator does not light.

5. Active Indicators

These blue LED's indicate that AC power is connected and the amplifier is turned on.

6. Protect Indicators

These red LED's indicate that the channel is in Protect mode. When the channel goes into protect mode all output for that channel will be muted. The protect LED's light when overheating or other severe problems occur. This is to protect any speakers connected to the channel. The LED's also light for approximately five seconds whenever the unit is powered on and fade slowly when the amplifier is powered off.

7. Channel input level control

These two 21-position detented potentiometers adjust input level for their respective amplifier channels. In Bridged Mono Mode, only channel 1 level control is used to adjust signal level. In Parallel Mode, both input level control are used to adjust signal level for their respective amplifier channels. At their fully counter-clockwise position, the signal is attenuated by more than 80dB. At their fully clockwise position, the signal is at maximum gain. When 0 dBu of signal arrives at the input jacks and the Channel input level controls are set to their fully clockwise position, the unit delivers full power output.

Cerwin-Vega! CXA-8 & CXA-10 AMPLIFIERS

CXA AMPLIFIER REAR PANEL DESCRIPTION

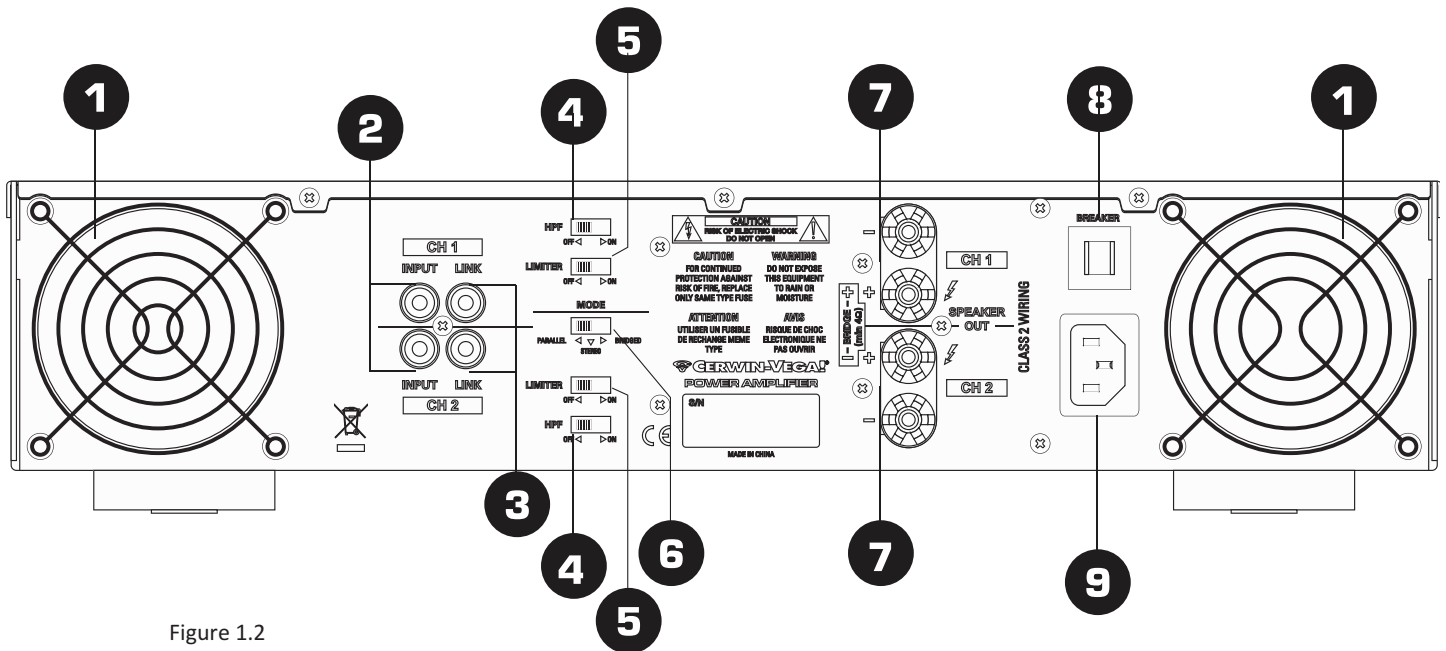

Figure 1.2

1. Fan

This is a variable speed cooling fan. Cool air enters the amplifier through the fan filters located on the front of the amplifier. Be sure not to block these ports when installing the amplifier or other equipment.

2. Input connectors

Connect the input source to the unbalanced RCA connectors using standard RCA cables.

3. Link connectors

These jacks are used to send a parallel signal to another device or amplifier.

4. High Pass Filter (HPF) switch.

These switches are used to activate the built-in High Pass Filter. The HPF rolls off signals below 40Hz. This improves bass performance by limiting sub-audio cone motion, making more power available for the speaker's rated frequency range. When the filter is turned off, a 5 Hz roll off protects against DC or deep sub-audio inputs.

5. Limiter switch

When the input signal connected to your amplifier is too high, you end up with a distorted output signal. To prevent this, both channels feature a clip limiter that can be engaged or disengaged selectively.

6. Bridge / Stereo / Parallel switch

This switch changes the amplifier operating mode between stereo, mono bridged, and parallel.

7. 5-way Binding Post

Connect each channel of the unit to your speakers. Binding posts are provided for each channel as so that paralleling of speakers is possible. Connection to the binding posts can be made with bare wire, banana plugs, or spade lug terminations. Make connections to both the Channel 1 and Channel 2 terminals for Stereo or Parallel Mode, or a single connection across the red terminals only of Channel 1 and Channel 2 for Bridged Mono Mode.

8. Circuit breaker

The breaker acts in place of common disposable fuses. This circuit breaker will trip if there is a fault with the main voltage or if maximum output is exceeded. Simply depress the circuit breaker and power up the unit again.

9. AC input

IEC connector for AC power cable. Connect the supplied heavy-gauge 3-pin IEC power cable.

PROTECTION

Every model in the CXA-Series incorporates protection features. The front panel Protection LED indicates the activity of the speaker connection relay circuitry in each channel. When the protection LED turns on, this circuitry is active, and all connected speakers are muted.

Initial power-up : For approximately five seconds after initial power-up, the protection circuitry is activated and the speaker outputs are muted. If everything is operating normally, you will hear an audible click at the conclusion of this brief period, as the protection circuitry is deactivated and the unit begins delivering signal to the connected speakers. It is normal for the Protection LED to fade gradually after the amplifier is powered off.

Thermal Protection : Abnormally high heat sink temperatures will engage the protection circuitry for the overheating channel only. An output relay disconnects the speakers until normal temperature range is restored. The Protect indicator will light to show the protection circuit is active. To guard against this problem, make sure the unit receives adequate ventilation on all sides and that both the front and rear panels are unobstructed. If the power transformer gets too hot, its thermal switch will disconnect all of the secondary power and disconnect both

channel outputs.

Short circuit : If output is shorted due to faulty wiring, the thermal circuitry will automatically protect the amplifier. If this occurs, the load will be disconnected by the thermal protection circuitry.

DC Voltage Protection : If an amplifier channel detects DC voltage at the speaker output, the output relay will immediately open to prevent speaker damage.

Subsonic Frequency Protection : The built-in High Pass Filter provides subsonic frequency protection for each channel.

Current limiting Protection : At the amplifier's full power limit, or clipping point, the limiter circuitry will be activated. This is indicated by illumination of the Clip LED. The channel gain is automatically reduced, protecting the speakers from high power. Uncontrolled feedback, oscillations, or improper equipment gain setting may activate this circuitry, which is virtually transparent in operation as full signal bandwidth is maintained.

There is reason to be concerned any time the Protection LED lights up (except for initial power-up during approximately five seconds). If this occurs, turn the amplifier off immediately and

SETUP

Clip limiter



Clipping is the result of an amplifier running into power supply limitation. The maximum output voltage that any amplifier can produce is limited by its power supply. Attempting to output a voltage (or current) level that exceeds the power supply limit will result in a flattening effect on the signal. A clipped waveform exhibits extreme harmonic distortion, making it sound harsh or dissonant. The clip limiter detects this and reduces the gain to minimize the amount of overdrive. To preserve as much of the program dynamics as possible, limiting reduces the average program level until peaks barely clip. Each channel has its own clip limiter, which can be switched on or off. When driving full-range speakers, clip limiting reduces high frequency distortion caused by bass overload. It also protects higher frequency drivers from excess overdrive and harsh clipping harmonics.

HPF (Hi-Pass Filter)



Also known as a low-cut filter, a High Pass Filter rolls off signals below 40Hz. The reproduction of the signal's bass portion is thus optimized, since ultra-low, distracting frequencies are eliminated, and more power is available for the reproduction of the wanted segment of the signal.

You should set up the filters so they best suit the frequency response of your speakers, since some speakers are particularly sensitive to over-exursion. The 40Hz filter works well with most compact full-range speakers.

SETUP (CONTINUED)

Mode Select

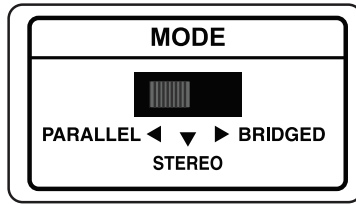

Stereo Mode

In stereo mode, both channels operate independently with individual input gain controls. Signal at channel 1's input produces output at channel 1, while signal at channel 2's input produces output at channel 2's output. Recommended minimum nominal load impedance for stereo operation is 2 ohms per channel.

Parallel Mode

When set to Parallel mode, a signal applied to channel 1's input will be amplified and appear at outputs for both channel 1 & 2. The parallel mode is well suited for applications in which driving two speakers with the same signal but with separate amplification. The 'Channel 1' and 'Channel 2' input gain controls individually control the output level on channels 1 and 2.

Bridged Mono Mode

Bridged mono mode straps both amplifier channels together to make a very powerful, single-channel monaural amplifier. One channel "pushes" and the other channel "pulls" equally, doubling the voltage, the peak power is quadrupled, and program power is roughly three times as high as that of the individual channel. Signal is applied to the channel 1 input only and channel 1 input gain control is used to adjust signal level. The input gain control belonging to channel 2 are not used.



Note : Bridged mono mode is to be used only when the CXA-Series is connected to a 4 or 8 ohms speaker load. Use of Bridged mode with speaker loads of less than 4 ohms can result in severe damage to the unit due to excessive heat and current limiting. Use extreme caution when operating the amplifier in Bridged Mono Mode. Never ground either side of the speaker cable; the speaker load must "float" away from the amplifier chassis.

CONNECTIONS

Stereo Mode

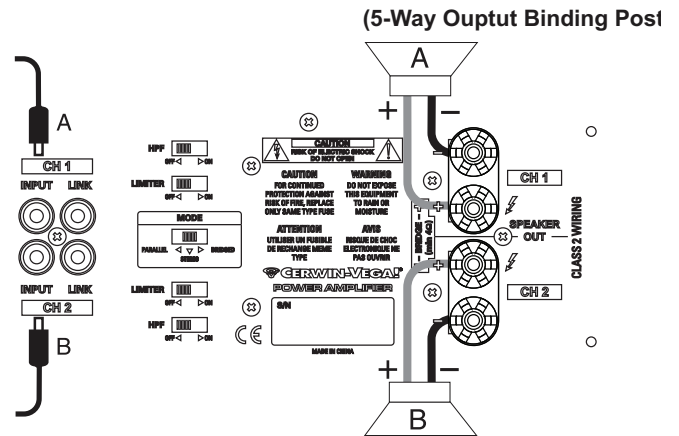

Parallel Mode

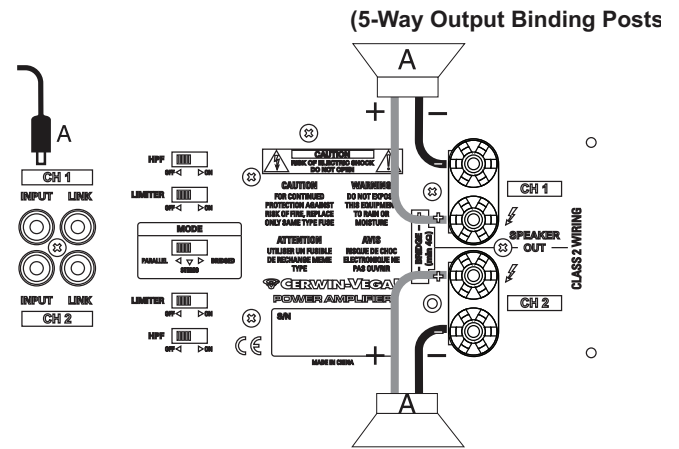

Bridged Mono Mode

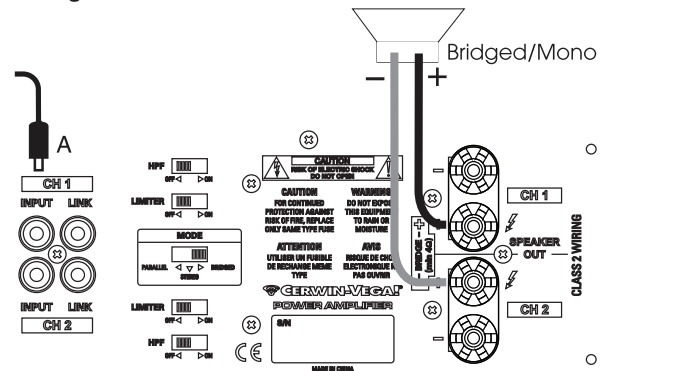

Cerwin-Vega! CXA-8 & CXA-10 AMPLIFIER SPECIFICATIONS

	CXA-8	CXA-10
Output Power (RMS)	Stereo Both Channels Driven	
8 ohms	400 W	600 W
4 ohms	600 W	900 W
2 ohms	900 W	1400 W
Output Power (RMS)	Bridged Mono	
8 ohms	1200 W	1800 W
4 ohms	1800 W	2800 W
Signal to Noise Ratio (20 Hz - 20k Hz)	102 dB	104 dB
Distortion (SMPTE-IM)	0.01%	0.04%
Input Sensitivity @ 8 ohms	4 dBu	4 dBu
Voltage Gain	33 dB	35 dB
Output Circuitry	Class AB	Class H
Current Consumption	120V / 230V	
@ 1/8 power @ 4 ohms	8.8 / 4.4 amps	6.8 / 3.4 amps
@ 1/3 power @ 4 ohms	12 / 6 amps	17 / 8.3 amps
@ Full power @ 4 ohms	19.5 / 9.5 amps	32 / 16 amps
Distortion		
20 Hz - 20k Hz @ 1/2 Power	0.01%	0.03%
1k Hz @ Full Power	0.10%	0.10%
FREQUENCY RESPONSE		
+/- 0.5 dB	20 Hz - 20 kHz	
+/- 3 dB	5 Hz - 60 kHz	
Damping Factor (400 Hz)	280	350
Input Impedance	15k ohm Un-balanced / 30k ohm balanced	
Input Clipping	22 dBu (10 Vrms)	
Cooling	Continuously variable speed fan, front to rear	
CONNECTORS		
Input	Unbalanced RCA input and link out	
Output	5-way binding post	
CONTROLS		
Front	AC power switch / Channel 1 & 2 volume	
Rear	HPF Switch / Limiter Switch / Mode Selector Switch	
Indicators	Power On: Light Blue / Signal: Dark Blue / Limit-Clip: Red	
Protection	Short Circuit / Thermal / Current Limit resetable breaker / DC offset / Current In-Rush / RF Protection / On-Off Mute	
Power Requirements	120V 60Hz (USA) / 230V 50Hz (EU)	
Dimensions	482 X 101 X 420 mm	
Net Weight	18 Kg	18.8 Kg



Cerwin-Vega! A member of the Gibson family of brands
Gibson Customer Service • 309 Plus Park Blvd. • Nashville, TN 37218
Phone: 1-800-4GIBSON (1-800-444-2766)
E-mail: info@cerwin-vega.com
www.cerwin-vega.com

LITH00023 CXA OWNERS MANUAL © 2012 CERWIN-VEGA ALL RIGHTS RESERVED

This document is copyright protected. No part of this manual may be copied or reproduced in any form without prior written consent from CERWIN-VEGA. CERWIN-VEGA shall not be liable for operational, technical, or editorial errors/omissions made in this document.